

# **NUCLEAR HEATED STEAM GENERATORS**

**B Y**

**D. J. STELLIGA — Chief Engineer**

**J. M. DYKE — Assistant Chief Engineer**

**Babcock & Wilcox Canada Ltd.**

**Galt, Ontario**



**Presented to:**

**CANADIAN ELECTRICAL ASSOCIATION**

**Toronto, Ontario**

**MARCH 9-12, 1970**

NUCLEAR HEATED STEAM GENERATORS

C.E.A. MEETING MARCH 1970

INTRODUCTION

The art of Power Plant Design is in a continuous state of development and the store of available knowledge for the design of the equipment involved is being enlarged each year and with every completed project.

When nuclear energy was first introduced, some may have thought that our entire accumulation of power plant knowledge would have become obsolete. Over the years it has been apparent that most of our familiar equipment and terminology has been retained. The knowledge we have gained in the past has been modified to meet new requirements in a slightly different environment.

We have realized that the experience gained in the boiler industry utilizing heat from various sources and employing various systems and concepts, complemented by the experience gained in the heat transfer and steam generation field, plus applied research has made it possible to design nuclear heated steam generators for various types of nuclear plants.

This paper will review some of the types of units either in service or for which conceptual designs are available and their application to the CANDU Cycle.

## NUCLEAR HEATED STEAM GENERATORS FOR PWR SYSTEMS

The majority of units to be discussed are employed in pressurized water cooled reactors (PWR). The primary fluid, water, heavy water flows over the reactor tube bundles, the heat of fission is picked up by the primary fluid and transported to the steam generators where the heat is given up to the secondary fluid, ordinary water, which is converted into steam for the turbines. The selection of the primary fluid, either heavy or light water, or liquid metal, as the case may be, is determined by the type of nuclear cycle employed. The temperature and pressure of the primary fluid leaving the reactor are set by the nuclear reactor core design parameters.

During the past eight to ten years in which Canada has been in the nuclear power generation field, there has been a steady development and improvement in the design and construction of steam generators for use with nuclear reactors for central station application. The most significant factor affecting cost reduction has been increased megawatt capacity.

### POT TYPE BOILER

Figure 1 shows the oldest and simplest steam generator a horizontal integral drum boiler or "Pot Type" unit. Primary water enters and leaves through the separate internal primary heads and tube sheets. Steam is formed on the outside of the tubes and rises to the surface above the tube bundle where it is removed from the water by natural separation at the steam water interface. Baffling is installed to provide a downcomer and thus assist circulation.

The location of the feedwater introduction is such that it mixes with the recirculation water before contacting the heating surface as in normal steam drum practice. The limitation of this type of unit is free surface separation of steam from water resulting in low steam quality and low capacity.

#### HORIZONTAL U TUBE STEAM GENERATORS

The horizontal U tube steam generator with a separate steam drum (Figure 2) using mechanical cyclone separation of steam and water evolved next to overcome the limitations of the "Pot Type" Boiler.

This type of generator was used at NPD Nuclear Station at Rolphton, Ontario to prove the practicability of the Canadian Nuclear Cycle. This single unit produces 300,000 lbs. of steam per hour from a U "shell-and-tube" heat exchanger employing 6,200 sq. ft. of 1/2" O.D. inconel tubing. The heavy water flowing from the reactor passes through the heat exchanger inside the tubes and the heat is transferred to the light water on the shell side causing it to boil. The steam-water mixture circulates upwards to the steam drum through the riser tubes and enters the cyclone separators. Steam is drawn off through the outlet header to the turbine and solid water is recirculated back down feeder tubes to the heat exchanger bundle.

This unit has been in service for 40,000 hours over an eight year period. Last Fall a leak was discovered in one of the tubes adjacent

to a baffle support. The exact cause of failure has not been established as the defective tube could not be removed from the unit. The tube was plugged and the unit has been returned to service to carry on experimental work in connection with the CANDU Cycle Development.

Steam generators of a similar configuration can be found in the Nuclear Ship Savannah, Shipping Port and Indian Point Nuclear Plants. The NPD heat exchanger was designed to meet the requirements of the ASME Code Section VIII, since the Nuclear Code as we know it was not in existence at that time.

#### Vertical U Shell & Tube Generator

Following the successful application of the NPD concept, the next station, namely Douglas Point, Fig. 3, a 200 MW full scale demonstration plant, employed multiple vertical U-tube U-shell heat exchangers with a separate steam drum for the free surface separation of steam with secondary dryers. This configuration was designed to employ the maximum possible LMTD using the outlet leg of the heat exchanger surface as an economizer. The hot leg of the U-tube heat exchanger being the boiling recirculating type circuit.

#### Recirculation Type Boiler

The desire to pack heating surface into less plan area, to generate more and more kilowatts in less space, and to keep the containment vessel to its smallest size, led to the next evolution in the configuration of CANDU nuclear heated steam generators - the vertical integral drum boiler or light bulb type generator. This configuration is the most commonly used in pressurized water reactor systems to day.

The vertical unit shown in Figure 4 combines in one enclosure both steam generation and separation equipment and is the type used for Pickering Station.

Primary fluid enters the bottom of one side of the divided primary head passes upward through the U tube and leaves the primary outlet nozzle on the opposite side. On the secondary side water enters the shell into the preheat section in the outlet leg of the primary side passes upwards and becomes heated to saturation temperature after which it boils and the steam water mixture passes up to the cyclone separators in the enlarged section of the unit.

From the cyclone separators, steam is discharged upwards through the scrubbers, where the entrained moisture is removed, and leaves the vessel through the steam outlet connection. This unit design results in an extremely compact nuclear heated steam generator. The tubes employed are alloy material, while the structural parts are carbon steel. The primary tubesheet face is clad with the same alloy as the tubes to facilitate seal welding.

The selection of tubing materials for nuclear heated steam generators is a topic which could form the subject material of a separate paper. The search is always on for better materials for application in the PWR. We will mention here only properties of the presently known candidates in order of their relative costs.

1. Carbon steel has been considered and has excellent potential, however, carbon steel is subject to pitting attack under lack of chemical control.
2. Monel has proven itself in nuclear service but tends to produce some copper activation products which are undesirable.
3. Incoloy appears to be an excellent material but there is no known relevant heat exchanger service.
4. Stainless steels were used in all the original PWR systems but stainless steel is subject to chloride stress corrosion.
5. Inconel is widely used and until recent months, had no known history of stress corrosion or other defects in service.

The evidence shows that the method of tube support design is critical if tube failures are to be avoided. The mechanism of failure of inconel is not yet fully established but local boiling to dryness initiates the attack. It can be shown that drilled support plates with parallel sides and small clearances around the tube can promote adverse conditions. The lattice bar type tube supports with line contact on the tubes and large open areas have proven to be successful and no failures are reported either from dryout or vibration.

In order to ensure maximum circulation stability under boiling conditions, Steam Generators of this type usually operate with a circulation ratio in the range of 4 to 10. This order of magnitude of circulation ratio also reduces the tendency of hide-out of various sections of the heating surface and boiling to dryness in these areas. With the arrangement of cyclone steam separating equipment, steam to the turbine can be guaranteed to have a quantity of 25% or better.

Velocities in the heating zone are relatively low, usually under 20'/second. Heat fluxes are maintained in the range where only nucleate boiling takes place and high coefficients of heat transfer result.

The economizer section is baffled to give increased mass flow and adequate heat transfer, however, the boiling takes place as pool boiling. Boiling heat transfer is not improved by the addition of baffles to direct the steam water mixture flow; in fact, it may be impeded because of the collection of steam bubbles under steam baffles in this area. Therefore, tube support in this area must be sufficiently open to allow the free passage of the steam water mixture upwards. Also, in order to maintain flow stability tube supports must have sufficient free flow area to give the lowest possible pressure drop on the boiling side and thereby keep the circulation ratio as high as possible in the range of 4 to 10 as indicated earlier in the paper.



### Direct Cycle Boiling Water Reactor

The next step in the advancement of the CANDU Cycle some smart design engineers said why not do away with the steam generators and reduce the cost, and they did, by producing the direct cycle Boiling Water Reactor, presently under construction at Gentilly, Quebec. With Direct Cycle units, it is essential to obtain high purity steam for the turbine. This can be accomplished in some cases by providing for adequate circulation and separation inside the reactor pressure vessel itself. Such a design is shown in Figure 5. The steam water mixture resulting from the boiling in the reactor core is directed through the cyclone separators, which function in the same manner as those used in boilers. Steam is carried directly to the steam turbine from the reactor outlet while the separated water, mixed with feedwater, is recirculated down through the annulus surrounding the thermal shields.

Another variation of this design, Figure 6, which is used in the Gentilly Station, involves the location of steam separating equipment in a separate steam drum which is supplied with the steam water mixture through riser tubes from the reactor. This mixture is directed through cyclone steam separators and the "solid" water is recirculated to the reactor core through downcomers. It is to be noted that the conventional steam plant in this cycle, operates under radioactive conditions.

The next step in the evolution of the CANDU Cycle is the 3,000 MW Bruce Generating Station on the shores of Lake Huron, consisting of 4 - 750 MW units).

Due to the special requirements as laid down by AECL, the normal "light-bulb" recirculation type steam generator has been modified somewhat. A long horizontal steam drum connects four inverted U-tube heat exchanger bundles. In this station then we see the combination of the proven recirculation type vertical U-tube steam generator coupled to a steam drum similar in its concept to the steam drum on a large utility boiler. Therefore in designing this equipment available knowledge in the already developed utility boiler field, can be used in conjunction with knowledge of nuclear heated steam generator design.

The units we have described briefly and generally show the development of nuclear heated steam generators in the industry and show how these designs were applied to the Canadian Nuclear Cycle.

#### Once-Thru Steam Generators:

Our American Company has designed and built a steam generator utilizing the once-thru concept or the OTSG Unit. In its simplest form this type of unit is a single tube exposed to a heat source. Feedwater is introduced into one end of the tube and if the temper-

ature of the heat source is high enough, superheated steam is emitted from the other end. This steam generator is usually characterized by high steam - water velocities, to minimize metal temperature variations along the tube. The quality of the mixture varies along the length of the tube, being zero at the inlet end and reaching 100% at some point in the length of the tube, at which point superheating commences.

In designing the steam generator, it is vital to make efficient use of the heat transfer surface. For this reason it is necessary to make the maximum use of nucleate boiling. In this type, boiling steam bubbles form where there are discontinuities in the heating surface. These bubbles break off and are carried away by the sweeping action of the steam-water mixture.

### BOILING

Nucleate boiling gives high heat transfer coefficients and makes possible the generation of steam with a minimum of heating surface. There is, however, another type of boiling called film boiling. It is characteristic by a film which appears adjacent to the heating surface. The film acts as a insulator, and greatly reduces the amount of heat transferred in a given surface area as well as increasing the metal temperature. This type of boiling depends on flow velocity of the steam-water mixture, the quality of the mixture and the rate of heat input. With the temperatures and pressures of the PWR cycle at the present time, most of the heat transfer takes place under

nucleate boiling conditions. With the ability to produce a low level of superheat in this type of unit, the steam separating equipment inherent with the recirculation type boiler is eliminated, and therefore these units can be designed to produce more megawatts per foot of diameter.

Figure 8 shows a sectional side view of the once-thru generating unit. Primary water enters the steam generator through the upper head, flows down through the tubes, and exits through the lower head. Feedwater enters the unit near the top of the vessel and is sprayed from an annular ring to be mixed with steam bled from the upper end of the boiling section before flowing down the annular downcomer into the tube bank. The flow of the steam-water mixture in the boiler section is upwards through the tube bank inside the shroud. No distinct water level is present in this design since the vapor content of the mixture increases almost uniformly until the quality reaches 100% and superheating begins. The superheater region at the upper end of the bank is closely baffled to obtain the high velocity and good cross flow necessary for efficient heat transfer in this region. Superheated steam leaves the unit through the outlet nozzle near the upper end of the shell.

This steam generator is a definite step forward in the evolution of PWR Plants. It has a number of significant advantages such as: A compact unit with high power rating which can be shipped by rail in

single capacities up to 400 MW, superheat, and the vertical configuration is a good natural circulating thermal siphon, which may be used for reactor decay heat removal. Figure 9. This also shows a rough size comparison.

The main disadvantage for the application of this unit to the CANDU cycle is that although the heavy water holdup in the tubes is comparable to the recirculation type unit, the holdup in the connecting piping is much greater, unless however, a vertical oriented reactor core were employed. The low level of superheat could increase the overall cycle efficiency.

Before going on to other aspects we would like to mention that our Company is also involved in the design and application of sodium cooled reactor cycles and Figure 10 shows a sodium heated boiler.

As in the design of fossil fuel fired boilers, there appears to be as many designs of nuclear heated steam generators as there are manufacturers or even more so. It is not the intent of this paper to go into detail of other designs, but we wish rather to revert back to some of the design considerations for nuclear heated steam generators and then perhaps take a look at some of the manufacturing operations. Figure 11.

## DESIGN STEPS NUCLEAR HEATED STEAM GENERATORS

### Thermal Design

In the thermal design of a nuclear heated steam generator the pressure temperature flow parameters are set by the reactor design on the basis of allowable fuel rod core temperature and heat pickup allowance across the reactor coolant channels.

Fig. 12 will illustrate a typical relationship between the terminal temperatures of the boiler and economizer heating surfaces relative to the primary fluid flows.

The upper line shows the primary fluid temperature drop across the unit while the lower line shows the secondary fluid temperatures.

The feedwater from the feed train is preheated in the economizer to saturation temperature and steam is generated by pool boiling in the body of the vessel.

For economical design and predictable performance under boiling conditions, the minimum temperature difference between the primary and secondary fluid, which occurs at the common point of the two heating surfaces, should not be less than approximately 10°F. This is known as the pinch point. Also there is a relationship between the turbine cycle efficiency, T-sat (throttle pressure) and the feed water temperature delivered to the heat exchanger.

The diagram will also indicate that minimum pumping power will be achieved with the greatest temperature drop on the primary side - inlet to outlet. This will adversely affect the available throttle pressure. The converse is true.

A precise study of the total system economics will determine the temperatures selected.

To achieve the smallest heating surface of the boiler and economizer the heat transfer rates on the tube side should be compatible with the boiling heat transfer rates. Thus, high tube side velocities are desirable to achieve this. This is limited by the allowable velocity for the tubing material selected, the cost of pumping power and the cost of the unit resulting. Having made this selection and knowing the terminal temperatures of the unit illustrated above, the unit can be sized.

#### Structural Design and Analysis of the Vessel

In order to meet the requirements of the ASME Code, Section III Class C, the primary side of the circuit must be designed to ASME Nuclear Code Section III and the Secondary Side to ASME Unfired Pressure Vessel Code Section VIII Division 1. The primary side of a "light-bulb" steam generator consists of the inlet head, tube-sheet and tubes while the secondary side consists of the shell upper

head lightbulb section and main steam outlet nozzle. The primary side of the steam generators must have a complete stress analysis and a stress report issued documenting this analysis.

Basically, the Power Boiler Code Section 1 or Unfired Pressure Vessel Code Division 1 Section VIII do not call for a detailed stress analysis but merely set the wall thicknesses necessary to keep the basic hoop stress below the tabulated allowable stress. They do not require detailed evaluation of the higher more localized stresses which are known to exist, but instead allow for these by the safety factor of four and a set of design rules. These simplified procedures are for the most part conservative for pressure vessels in conventional service and a detailed analysis of many pressure vessels constructed to the rules of Section VIII would show where the design could be optimized to conserve metal. However, in vessels to be used in severe types of service such as highly cyclic types of operation, for services which require superior reliability, or for nuclear service where periodic inspection is usually difficult sometimes impossible, additional design considerations are required. The development of analytical and experimental techniques, and the use of computers, has made it possible to determine stresses in considerable detail. Therefore, the Section III Nuclear Code has in effect, a nominal safety factor of 3 on the primary membrane, or hoop stress, since this stress is limited to one third of the ultimate tensile strength or two thirds of the yield strength. However, this code requires the investigation of all primary and secondary stresses along with peak stresses to give a complete picture of the stress



system in a pressure vessel. The background reasoning for these changes are given in other documents and we do not intend to go into these in detail here other than to say that complete stress analysis work must be done requiring the use of a computer and the availability of design programs to analyze and prove that stresses are within the stated limits for the primary pressure parts. This design work on nuclear heated steam generators is done in our engineering offices in Galt and requires many thousands of hours. It cannot be said that a primary vessel built to Section III is designed before it is built, it is sized before the material is ordered, but the design process continues during the engineering and manufacturing.

#### CONCLUSION

We have endeavoured to highlight the development of nuclear heated steam generators as applied to the CANDU CYCLE. We have touched upon similar designs relating to this development and have discussed briefly the thermal design and stress analysis involved.

## BIBLIOGRAPHY

1. Nuclear Heated Boilers, R. C. Barnett & B. N. McDonald,  
American Power Conference March 1960.
2. Nuclear Steam Generators by D. K. Davies, American Power  
Conference April 1965.
3. Shop Fabrication and Quality Control Techniques for Massive  
Nuclear Vessels by A. T. Fragumen, American Power Conference  
April 1967.
4. Modern Techniques In Design and Analysis of Nuclear Pressure  
Vessels by D. K. Davies, American Nuclear Society June 1966.
5. Criteria of the ASME Boiler & Pressure Vessel Code for  
Design by Analysis in Sections III and VIII, Division 2,  
1969.

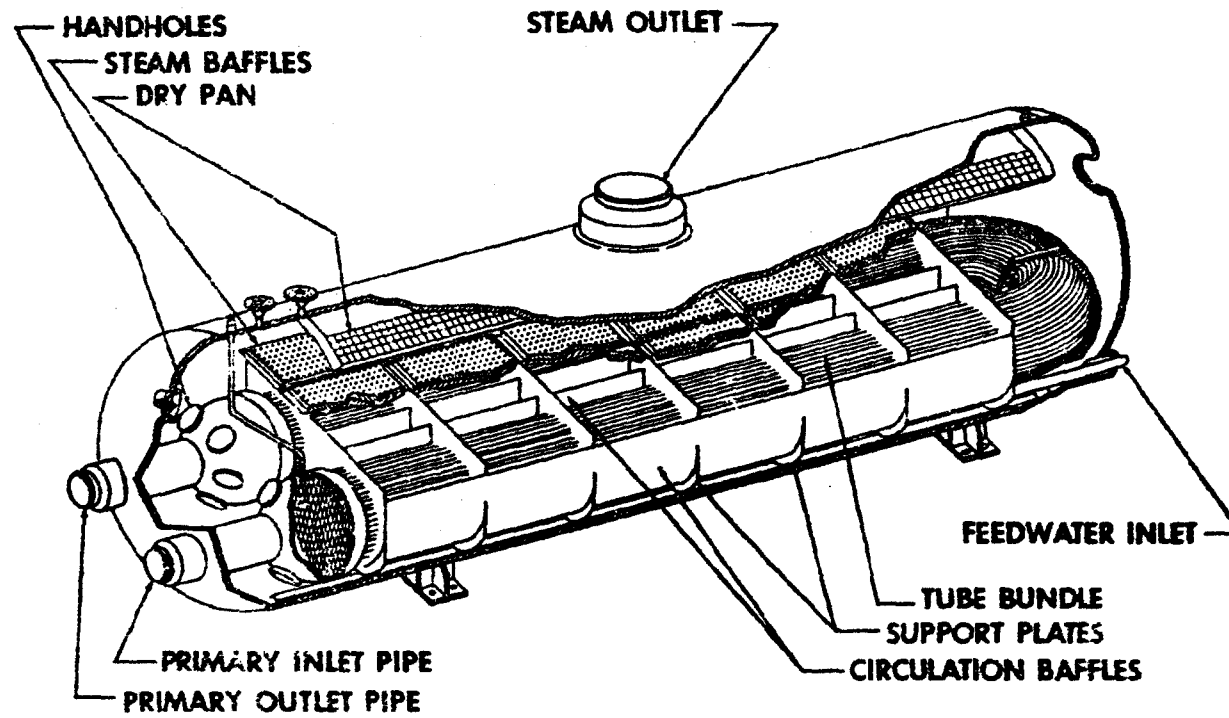

**HORIZONTAL INTEGRAL DRUM BOILER**

**FIG. N° 1**

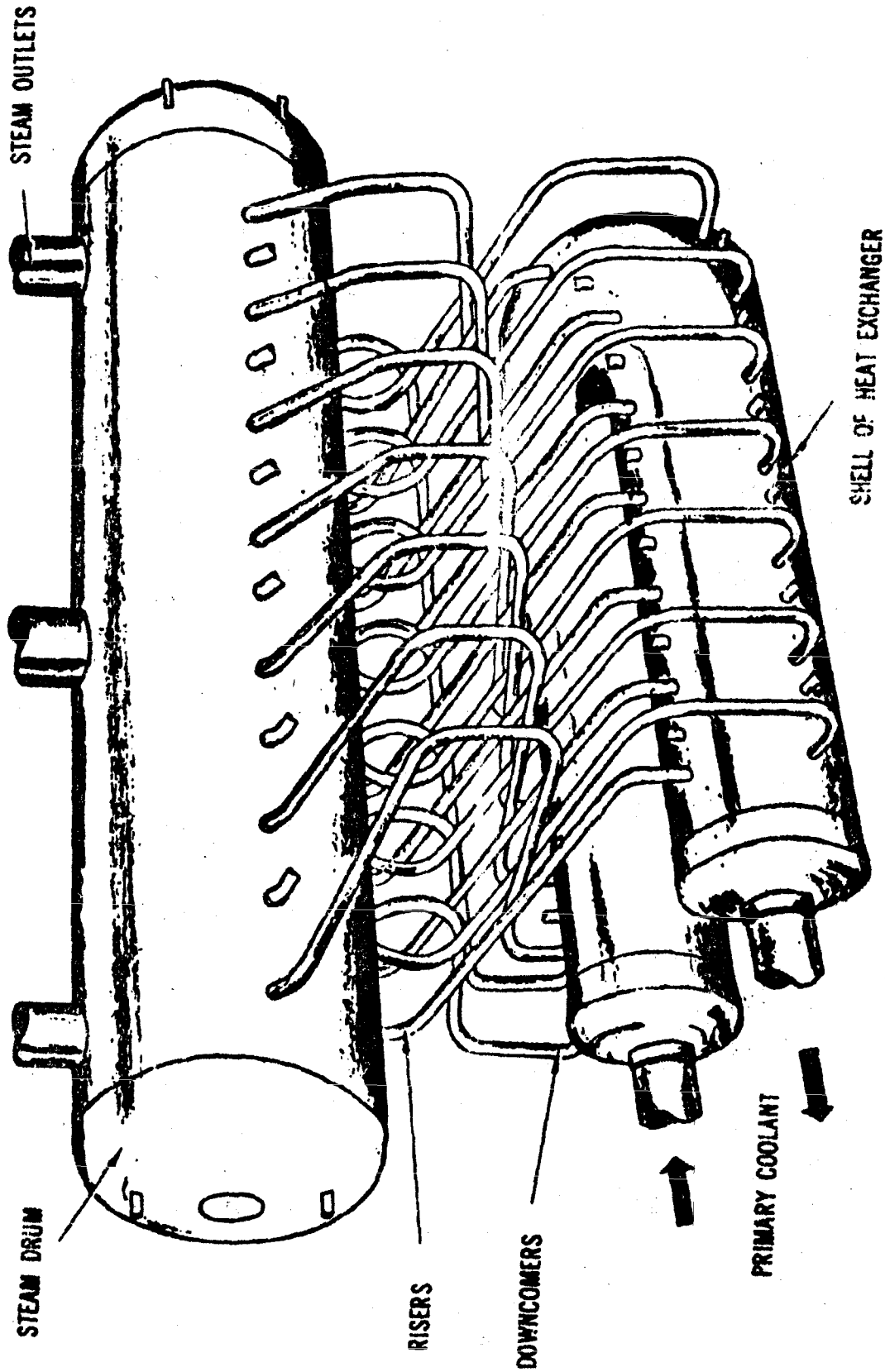

HEAT EXCHANGER & STEAM DRUM

FIG. N° 2

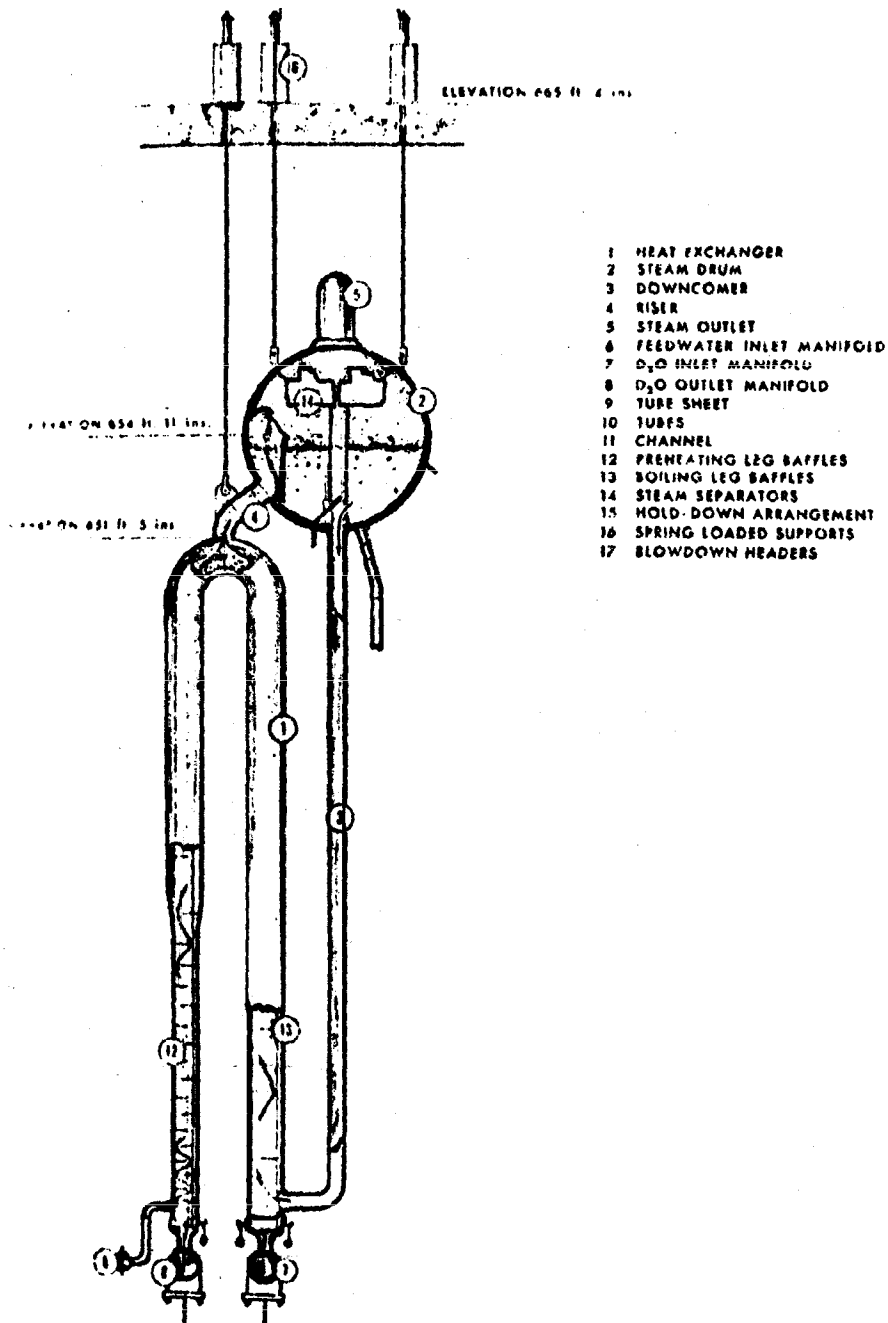
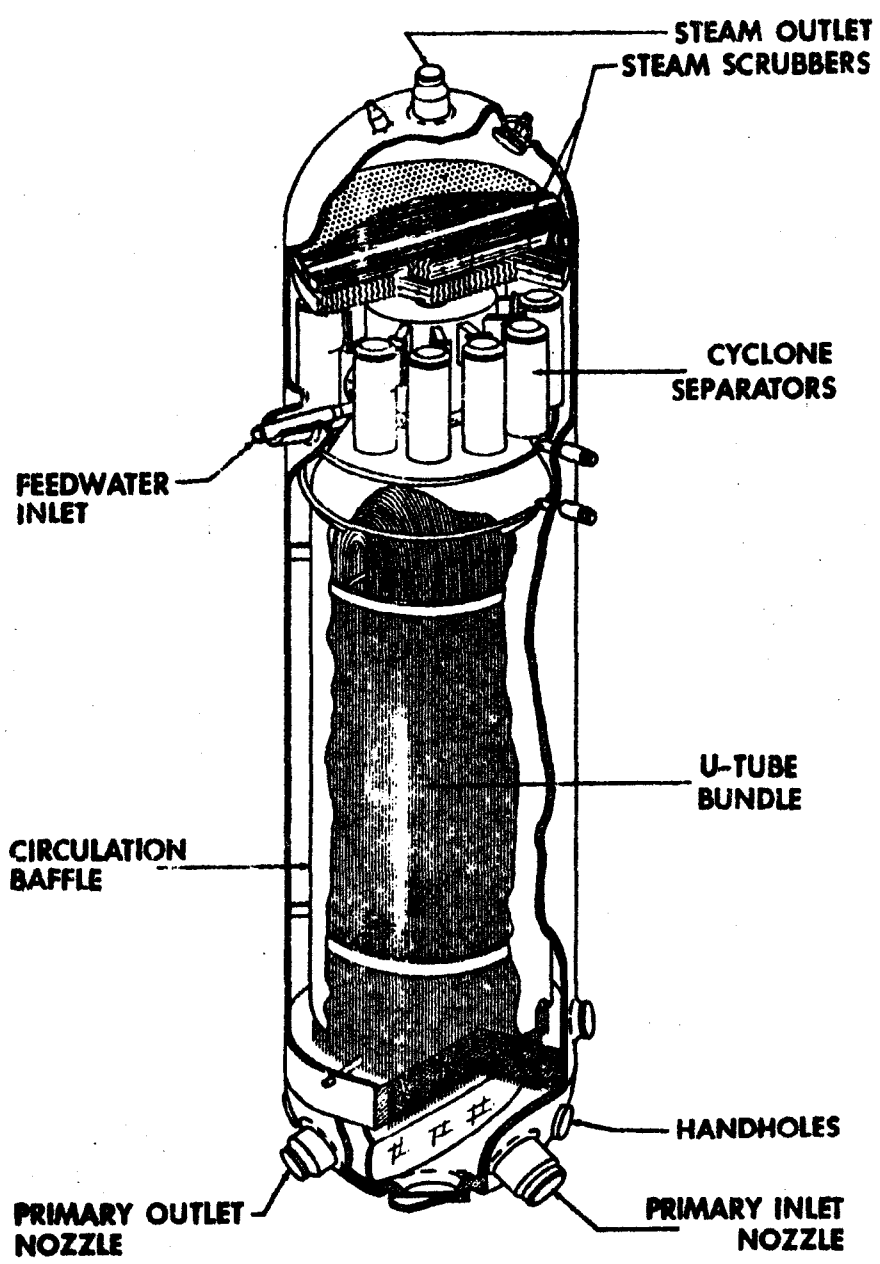

FIG. N° 3



**VERTICAL INTEGRAL DRUM BOILER**

**FIG. N° 4**

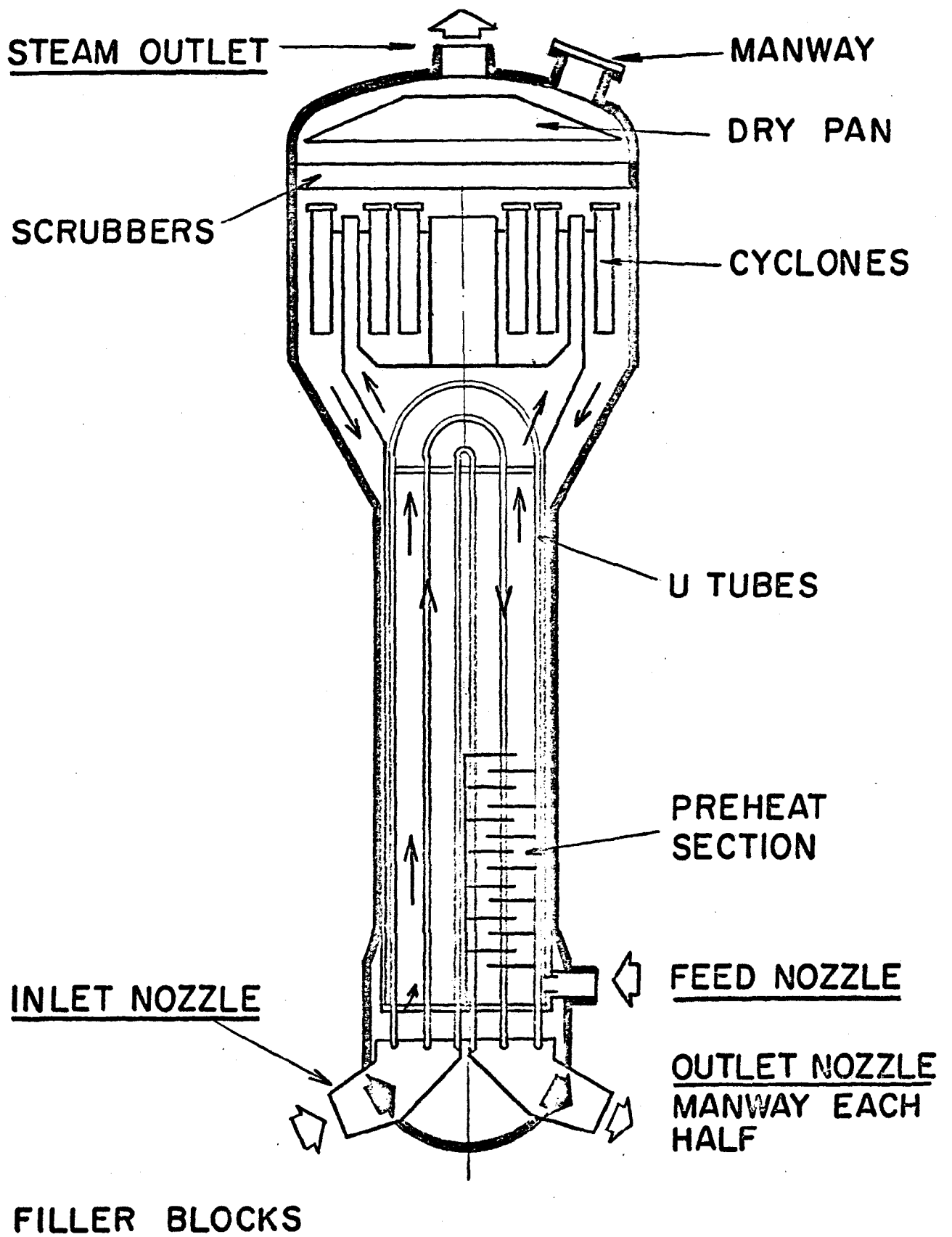
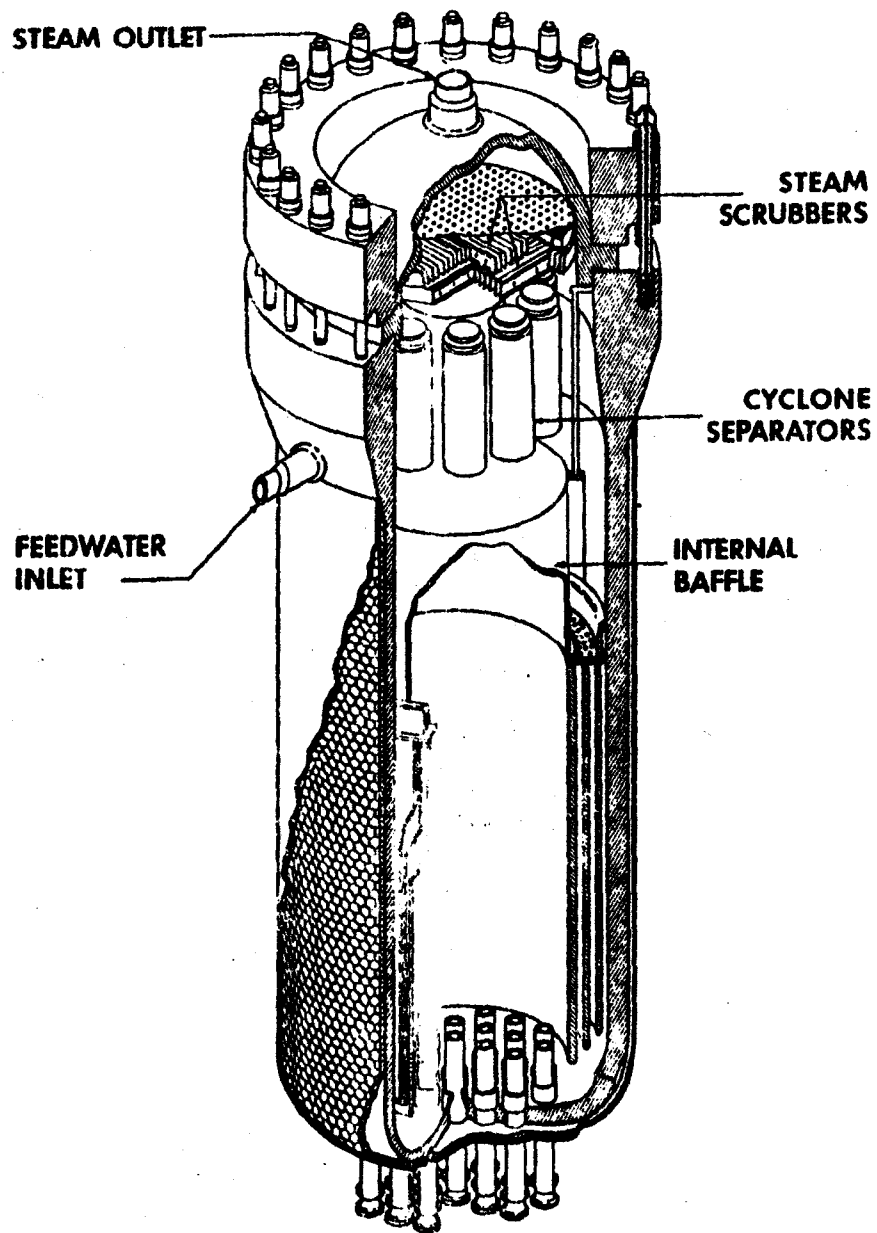

FIG. N° 5



**BOILING WATER REACTOR**

**FIG. N° 6**



# FLOW DIAGRAM OF GENTILLY NUCLEAR POWER STATION

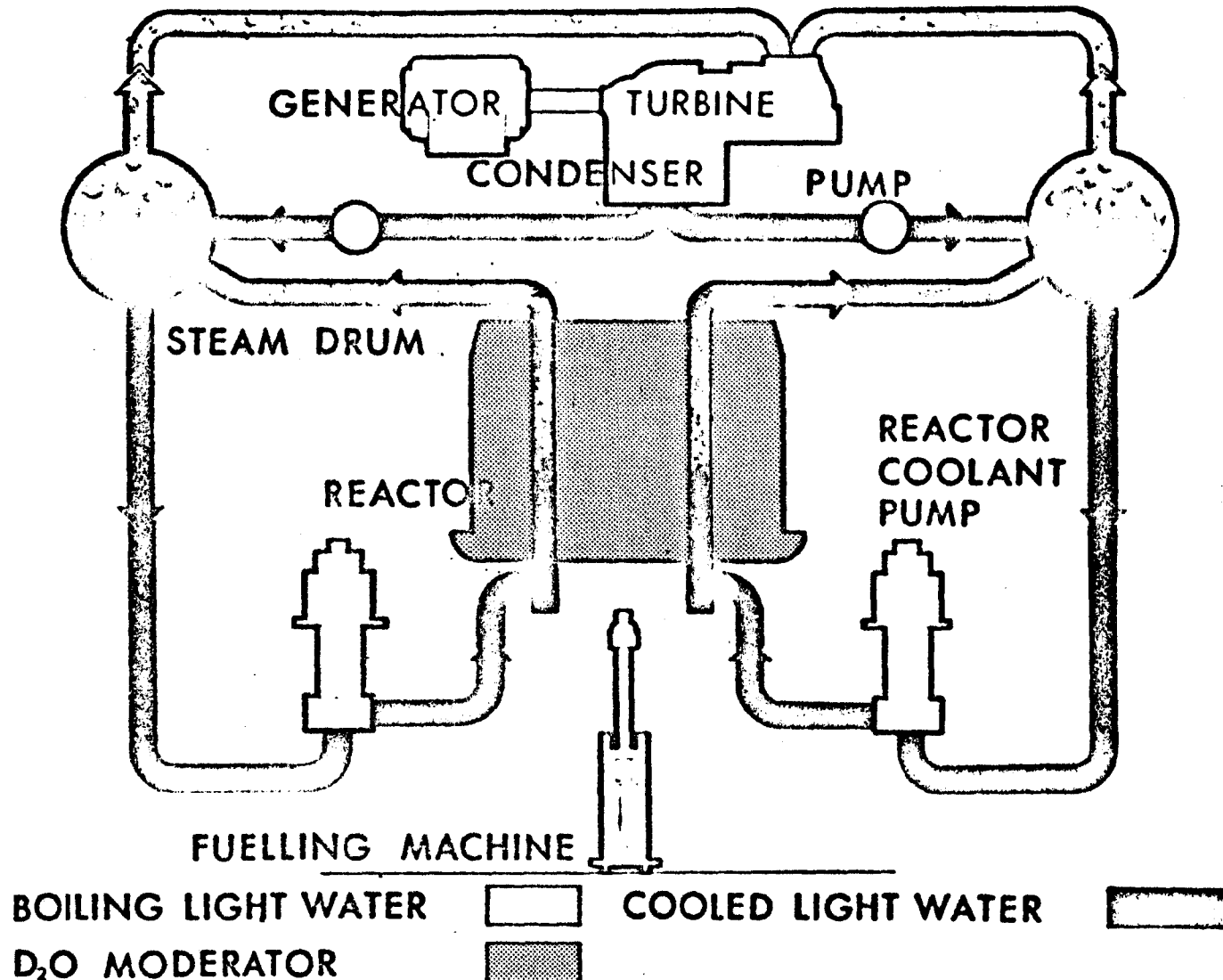

FIG. N° 7

Feedwater and Steam Flow in the OTSG

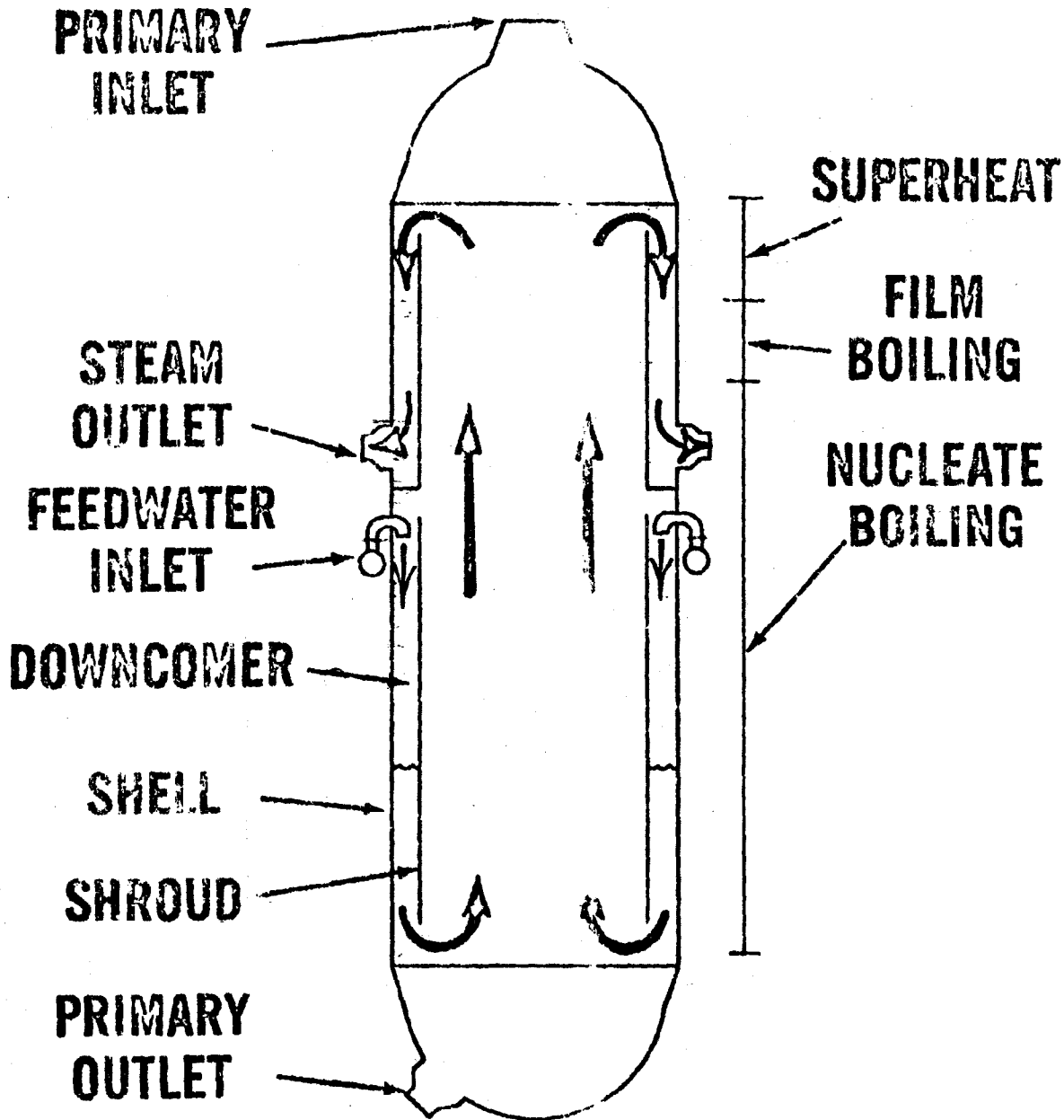

FIG. N° 8

Recirculating and Once-Through Boilers

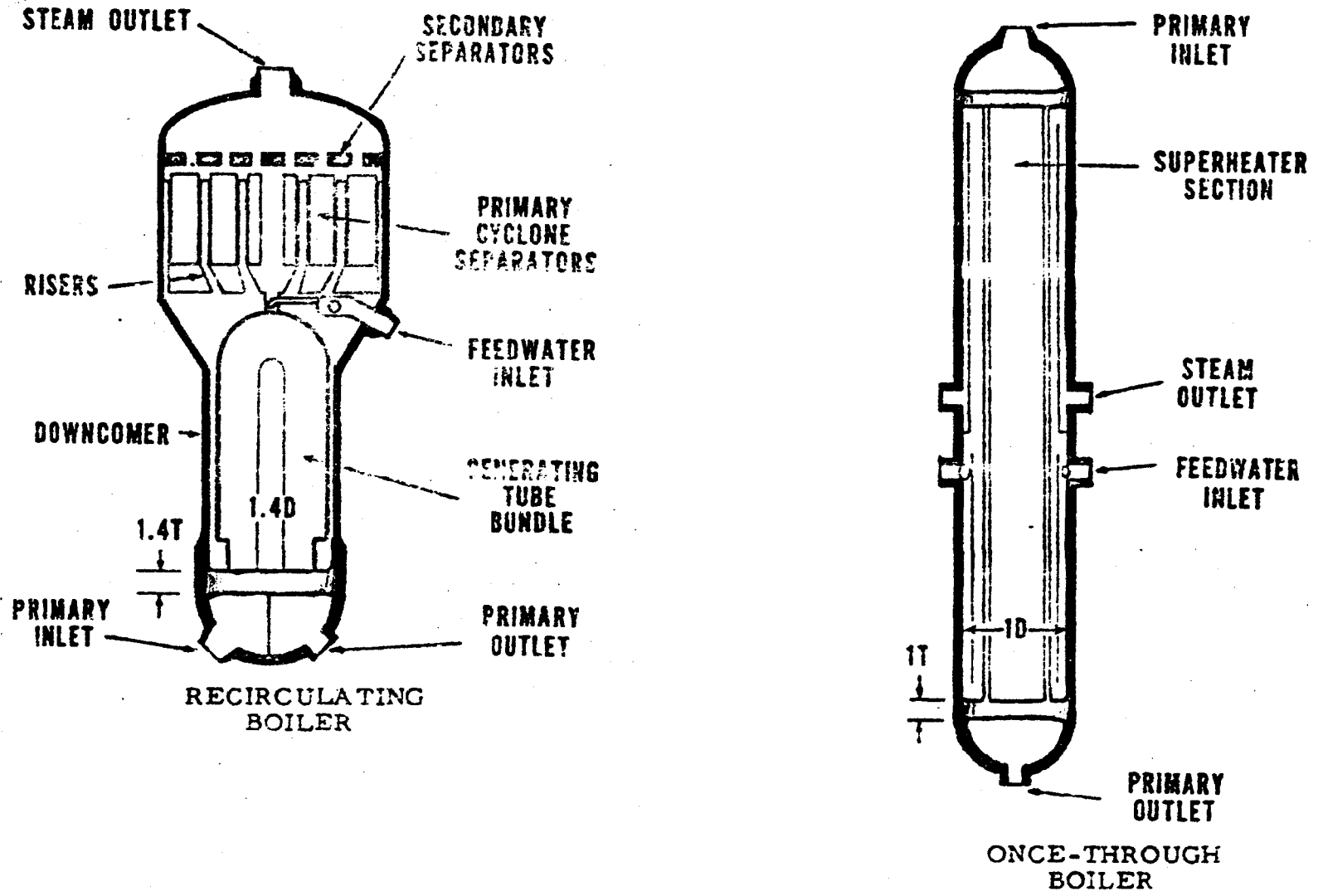
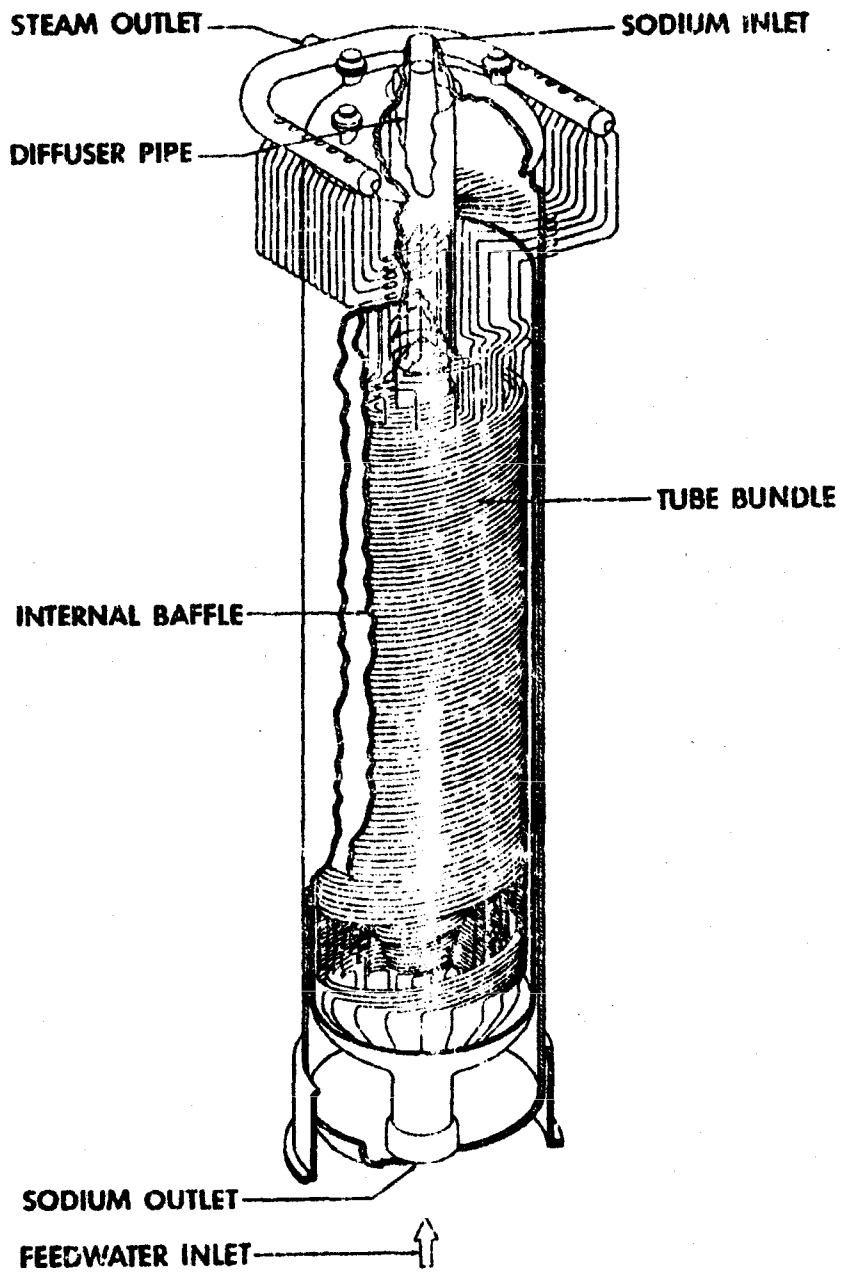

FIG. N° 9



**SODIUM HEATED ONCE-THROUGH BOILER**

**FIG. N° 10**