

Electrical Equipment - Course 230.2

GENERATORS: PART 2

EQUIVALENT CIRCUITS

1. OBJECTIVE

The Student must be able to:

1. Explain:
 - (a) how a generator's equivalent circuit is obtained.
 - (b) why the simplified equivalent circuit will, for most purposes, give satisfactory results.
2. Explain the operation of a generator when it is taken from the off load state to full load at:
 - (a) 1.0 pf.
 - (b) lagging pf.
 - (c) leading pf.

2. INTRODUCTION

It is possible to explain the actions of a generator by using magnetic flux diagrams as shown in the previous lesson 230.25-1. However, it is often easier to represent the actions of a generator, as it is loaded, by considering the generator's equivalent circuit.

In this lesson, the generator's magnetic behavior and equivalent circuits are considered for the following conditions:

- (a) 1.0 pf load. This type of load occurs when a generator is loaded with resistive loads.
- (b) lagging pf load. This type of load occurs when a generator is loaded, for example, with induction motors.
- (c) leading pf load. This type of load occurs when a generator has a resistive and capacitive load. The capacitance could be due to lightly loaded power lines.

Vector diagrams for conditions a, b and c are shown in the Appendices.

3. EQUIVALENT CIRCUIT

3.1 Off Load Equivalent Circuit

The magnitude of the emf E induced in a generator is, for a given speed, dependent upon the magnitude of the magnetic flux cutting the stator conductors. When the generator is off load, this induced voltage E is not affected by voltage drops within the generator and appears at the generator terminals, as the terminal voltage V_T , see Figure 1.

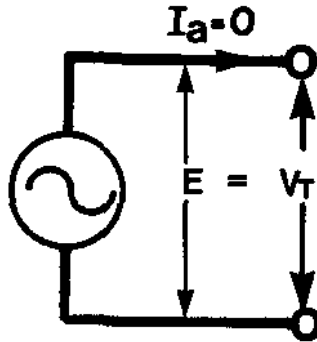

Figure 1: Equivalent circuit of generator on no load.

3.2 On Load Equivalent Circuit

As a generator is loaded, current flows in the stator conductors and creates the armature flux ϕ_A . This flux ϕ_A combines with the flux produced by the rotor. The combination of ϕ_F and ϕ_A gives the resultant flux ϕ_R which passes through the stator iron. The stator conductors produce the terminal voltage V_T , when they are cut by the resultant flux ϕ_R .

In the generator on load equivalent circuit, the magnitude of the induced emf E is, for a given speed and rotor flux ϕ_F , assumed to be constant. The generator internal volt drop, caused by the armature flux ϕ_A , is represented by the load current I_a flowing through a series reactance X_a , (X_a being the armature reactance due to armature reaction). When the load current I_a flows through X_a , it causes the voltage drop $I_a X_a$, see figure 2.

The windings in a generator also have leakage reactance X_L (which is largely due to the fluxes surrounding the endwindings which are outside the core). The stator windings also have resistance R_a which is small compared with X_a and X_L . When load current I_a flows through X_L , a voltage drop $I_a X_L$ occurs. Similarly, when I_a flows through R_a , a voltage drop $I_a R_a$ occurs.

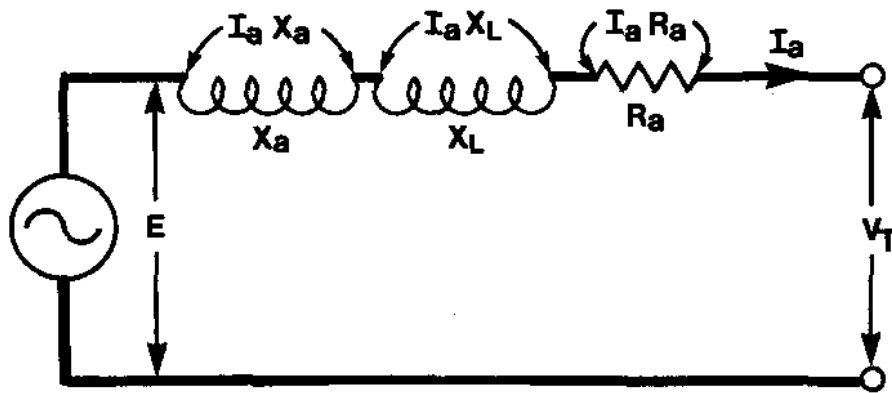

E = generated voltage.
 X_a = reactance due to armature reaction.
 X_L = reactance due to winding reactance.
 R_a = winding resistance.
 I_a = load current.
 V_T = phase terminal voltage.

Figure 2: Per phase equivalent circuit for a generator.

Figure 2 can be simplified to the diagram shown in Figure 3. X_a and X_L , because they are both reactances, can be "lumped together" forming X_d . X_d is known as the generator synchronous reactance. The term "synchronous" is used because this is the reactance of the generator at its synchronous speed - as distinct from standstill or any other speed. R_a , because it is very small compared to X_d , is neglected in this lesson.

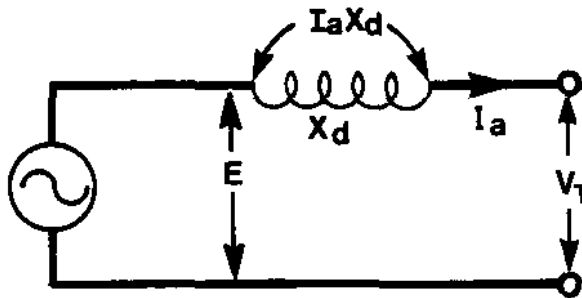

E = generated voltage.
 X_d = generator synchronous reactance.
 Note that as R_a is small compared to X_d , it is neglected.
 I_a = load current.
 V_T = phase terminal voltage.

Figure 3: Simplified per phase equivalent circuit for a generator.

4. GENERATOR OPERATING AT 1.0 pf LAG AND 0.9 pf LEAD4.1 Generator Operating at 1.0 pf

Figure 4(a) shows the flux pattern produced in the generator when it is loaded at 1.0 pf.

Note the following:

- (a) The current I_a and terminal voltage V_T are in phase. This is because the load is resistive.
- (b) Applying more electrical load requires more power input (ie, torque) from the turbine. This increased torque stretches the lines of flux coupling the rotor to the stator.
- (c) This stretching action weakens the flux produced by the rotor. Consequently the output voltage drops. To keep the terminal voltage V_T constant, the field flux hence E must be increased.

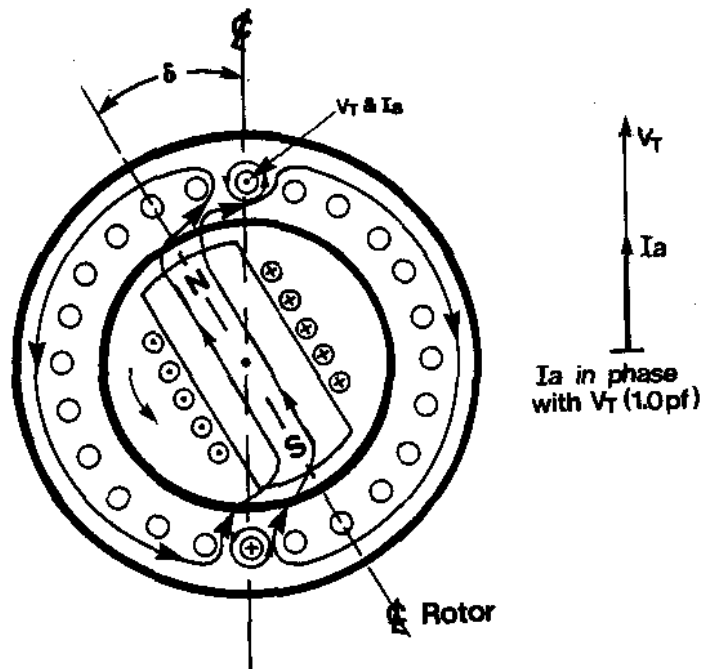

Figure 4(a): Generator on load at 1.0 pf.

Another way of representing the effects shown in Figure 4(a) is to consider the equivalent circuit of a generator supplying a 1.0 pf load. As the generator load current increases, the induced voltage E , now assumed to be constant, is reduced by the voltage drop $I_a X_d$. This gives a lower terminal voltage V_T . To keep V_T constant as the load increases, the field flux and hence E must be increased.

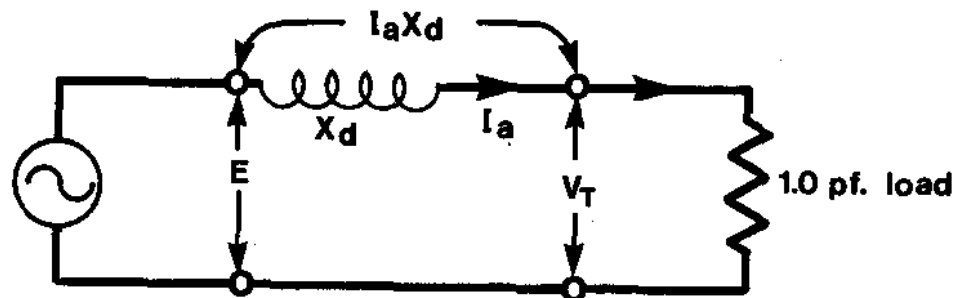

Figure 4(b): Equivalent circuit of a generator supplying a 1.0 pf Load.

A vector representation of Figure 4(b) is shown in Appendix 1 (see Figure 7).

4.2 Generator Operating at 0.9 pf Lag

Figure 5 shows the flux patterns produced in the generator when it is operating at 0.9 pf lag (25.8°).

Note the following:

- (a) The generator is supplying a lagging pf load and the current I_a lags V_T by θ where $\theta = 25.8$ degrees.
- (b) Because the load current I_a is now lagging V_T , the magnetic lines are stretched more than they were in the 1.0 pf condition. This further stretching produces further field weakening. To compensate for this the rotor current and hence flux must be increased compared with the 1.0 pf condition.
- (c) Because the stator current is lagging the terminal voltage V_T , the fluxes produced in the stator are also lagging. This effect causes all the fluxes to lag more and give a smaller load angle δ .

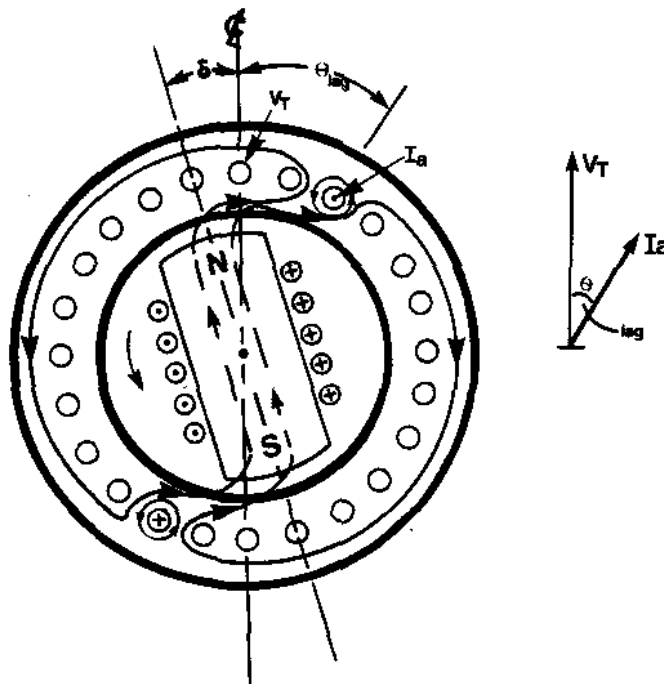

Figure 5(a): Generator on load at a lagging pf.

The effects shown in Figure 5(a) can be represented by an equivalent circuit, see Figure 5(b). The generator is delivering the same value of active current (MW load) as shown in Figure 4(b). In addition, the generator is now called upon to deliver a lagging reactive current (lagging Mvar load) and the resulting power factor becomes 0.9 pf lag. Note how:

- (a) the load determines the generators operating power factor.
- (b) the load current I_a consists of the resultant sum of the current through the resistor I_R and the current through the inductor I_L .
- (c) the load current I_a has increased in magnitude.

The larger lagging current I_a , flowing through X_d , produces a larger voltage drop than the current in the 1.0 pf condition. (A lagging current flowing through an inductive reactance produces a large voltage drop, see course 226.0.) Consequently the terminal voltage V_T will drop further. To compensate for this effect and keep V_T constant, the field current and hence E must be increased, compared to the 1.0 pf condition.

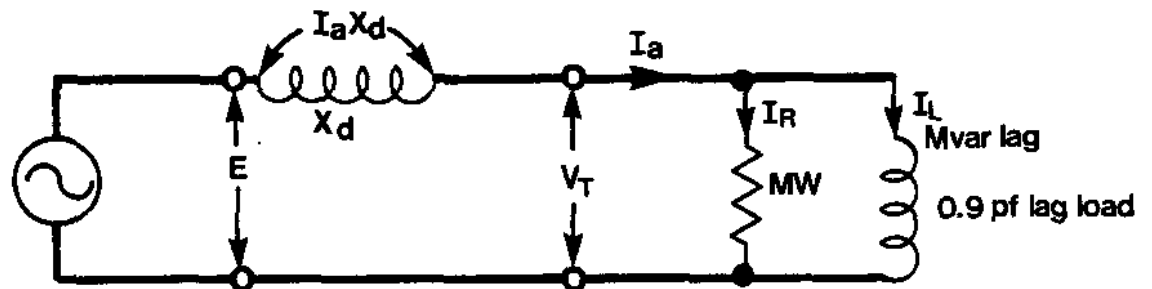

Figure 5(b): Equivalent circuit of a generator supplying a 0.9 pf lag load.

A vector representation of Figure 5(b) is shown in Appendix 2 (see Figure 7).

4.3 Generator Operating at 0.9 pf Lead

Figure 6(a) shows the flux patterns produced in the generator when it is operating at 0.9 pf lead, (25.8°).

Note the following:

- (a) The generator is supplying a leading pf load and the current I_a leads V_T by θ where $\theta = 25.8^\circ$.
- (b) Because the load current I_a is now leading V_T , the magnetic lines are stretched less than they were in the 1.0 pf condition. This reduced stretching produces less field weakening. To compensate for this, the rotor current must be reduced compared with the 1.0 pf and 0.9 pf lag conditions.
- (c) Because the stator current is leading, the fluxes produced in the stator are also leading. This effect causes all the fluxes to lead more and give a larger load angle δ .

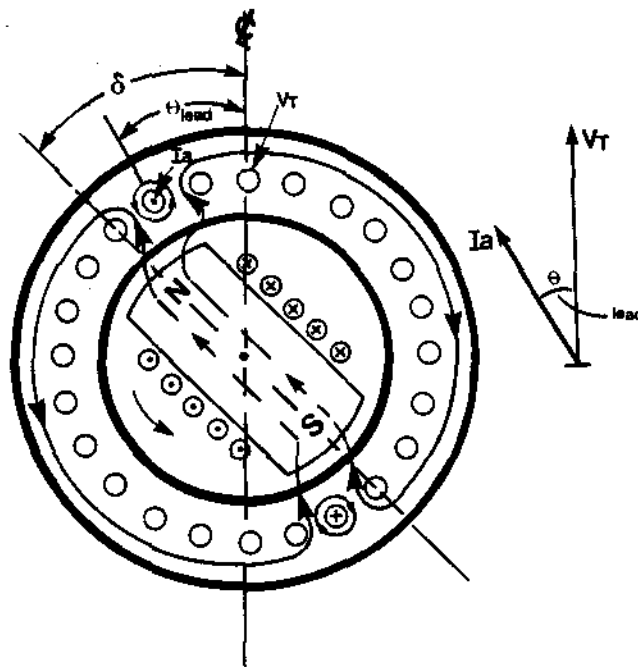

Figure 6(a): Generator on load at a leading pf.

Again, the effect shown in Figure 6(a) can be represented by an equivalent circuit, see Figure 6(b). The generator is delivering the same value of active current (MW load) as shown in Figure 4(b). In addition, the generator is now called upon to deliver a leading reactive current (leading Mvar load) and the resulting power factor now becomes 0.9 lead. Note how:

- (a) the load determines the operating power factor of the generator.
- (b) the resultant load current I_a has the same magnitude as that shown in Figure 5(b).

The leading current flowing through X_d produces a smaller voltage drop than in the 1.0 pf condition. (A leading current flowing through an inductive reactance produces a small voltage drop and in some cases a voltage rise, see course 226.0.) Consequently, the terminal voltage drop will be less or may even increase. To compensate for this effect, the rotor current must be reduced compared with that required for the 1.0 pf or the 0.9 pf lag conditions.

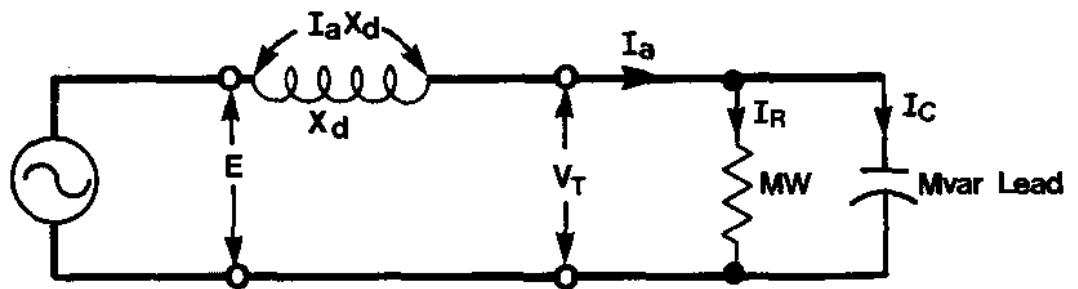

Figure 6(b): Equivalent circuit of a generator supplying a 0.9 pf lead load.

A vector representation of Figure 6(b) is shown in Appendix 3 (see Figure 9).

APPENDIX 1

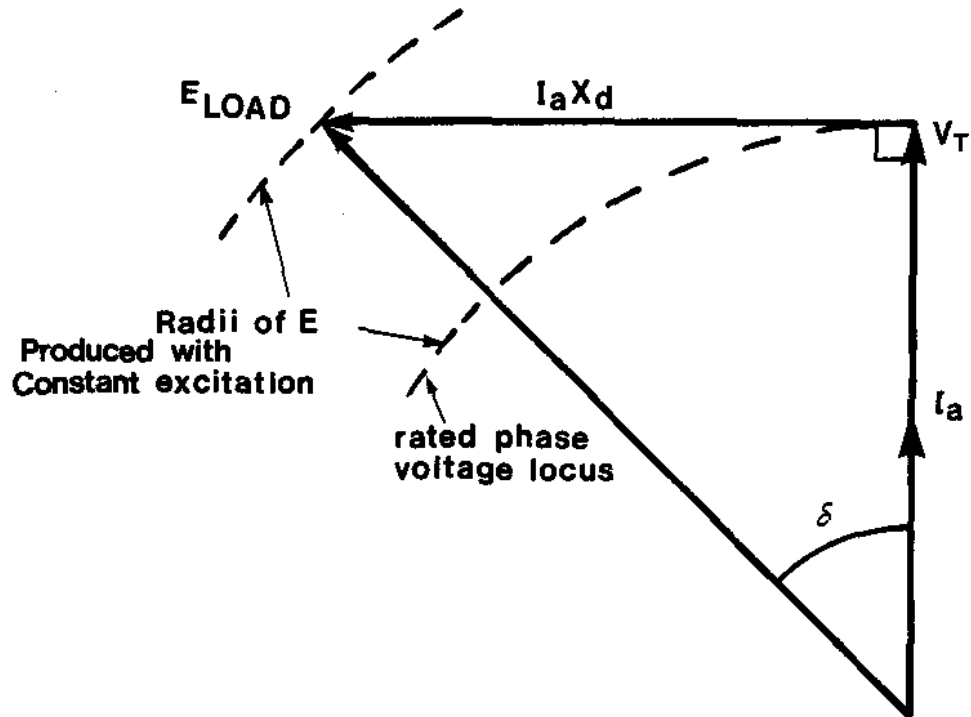

Figure 7: Vector diagram showing a generator on full load 1.0 pf.

Note the following:

- (a) As the generator is loaded onto a resistive load, the pf = 1.0 and I_a is in phase with V_T .
- (b) Because X_d is purely reactive, I_a must lag $I_a X_d$ by 90° . Therefore the $I_a X_d$ vector is at 90° to the I_a vector.
- (c) As the generator is loaded, to keep the terminal voltage constant, the generator voltage E has to be increased. This is done by increasing the rotor current. Note E load is greater than E off load.

APPENDIX 2

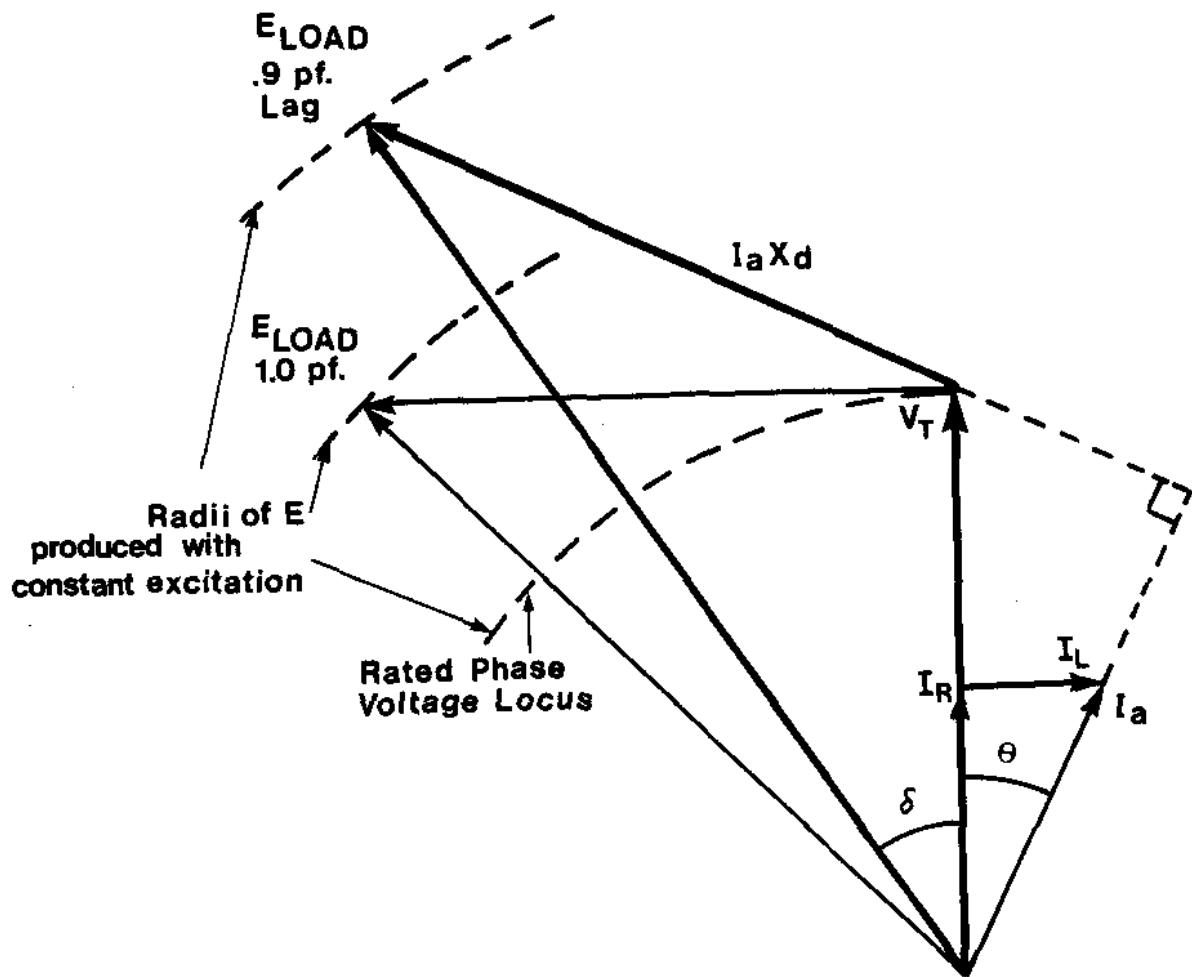

Figure 8: Vector diagram showing a generator on full load at 0.9 pf load. The MW load is the same as in Figure 7.

Note the following:

- As the generator is operating at 0.9 pf lag, the I_a vector lags the V_T vector by θ° .
- The $I_a X_d$ vector is at 90° to the I_a vector.
- As the generator is being loaded from 0 load to same MW load as Figure 7 but with pf = 0.9 lag, to keep the terminal voltage V_T constant, the generated voltage E has to be increased. This is done by increasing the rotor current. Note E load 0.9 pf lag is greater than E load at 1.0 pf.

APPENDIX 3

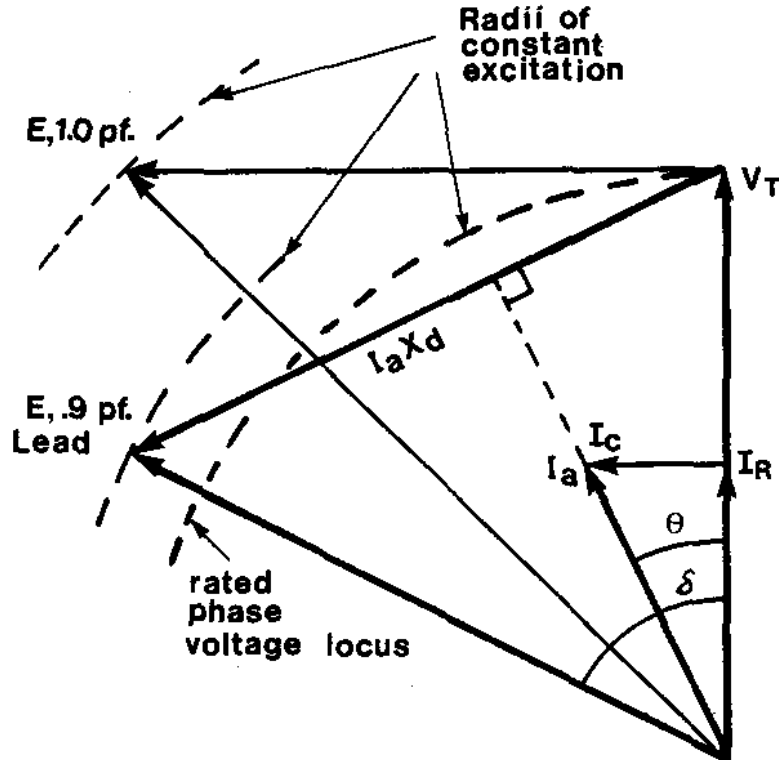

Figure 9: Vector diagram showing a generator on full load at 0.9 pf lead. The MW load is the same as in Figure 7.

Note the following:

- As the generator is operating at 0.9 pf lead, the I_a vector leads the V_T vector by θ° .
- The $I_a X_d$ vector is at 90° to the I_a vector.
- As the generator is being loaded from 0 load to same MW load as Figure 7 but pf = 0.9 lead, to keep the terminal voltage V_T constant, the generated voltage E has to be **decreased** relative to the 0.9 pf lag and 1.0 pf conditions. This is done by reducing the rotor current. Note E load 0.9 pf lead is less than E load pf = 1.

ASSIGNMENT

1. Draw and label the equivalent circuit for a generator on load and explain why the simplified equivalent circuit gives satisfactory results.
2. Draw and label a diagram showing the rotor current, the fluxes and the output voltage for a generator on full load, 1.0 pf.
3. A generator is supplying a local load at 0.9 pf lag and at the same time it is feeding the grid at 0.9 pf lag via a tie line. The tie line trips. Explain what must happen to the excitation on the generator to maintain the terminal voltage constant:
 - (a) immediately after the line trips.
 - (b) sometime after the line has tripped and when the:
 - (i) MW of the local load increases at 0.9 pf lag.
 - (ii) MW of the local load decreases at 0.9 pf lag.
 - (iii) MW of the local load remains the same but the pf becomes more lagging.
 - (iv) MW of the local load remains the same but the pf becomes more leading.
4. A generator is supplying a local load at 0.8 pf lag and at the same time feeding the grid at 1.0 pf via a tie line. The tie line trips. Explain what must happen to the excitation.
 - (a) immediately after the tie line trips.
 - (b) sometime after the tie line has tripped and when the:
 - (i) MW of the local load increases and the pf becomes 1.0.
 - (ii) the MW of the local load decreases and the pf becomes 0.7 lag.

J.R.C. Cowling