

CHAPTER 2: ELECTRONIC CONTROL

MODULE 3: CONTROL AND PROCESS CONSIDERATIONS

Ideally, a control system should be able to hold the process at the desired operating point by suitably changing the manipulated variable. Consider again the level control of an open tank with the control valve located on the inflow line. If the system was subjected to a sudden step demand increase (activate pump 1), the level would begin to drop away from the set point. A proportional controller would respond to this error and eventually stabilize the level at some offset position.

It would be worthwhile to consider a graphical representation of the level response, and the resulting inflow following the applied disturbance.

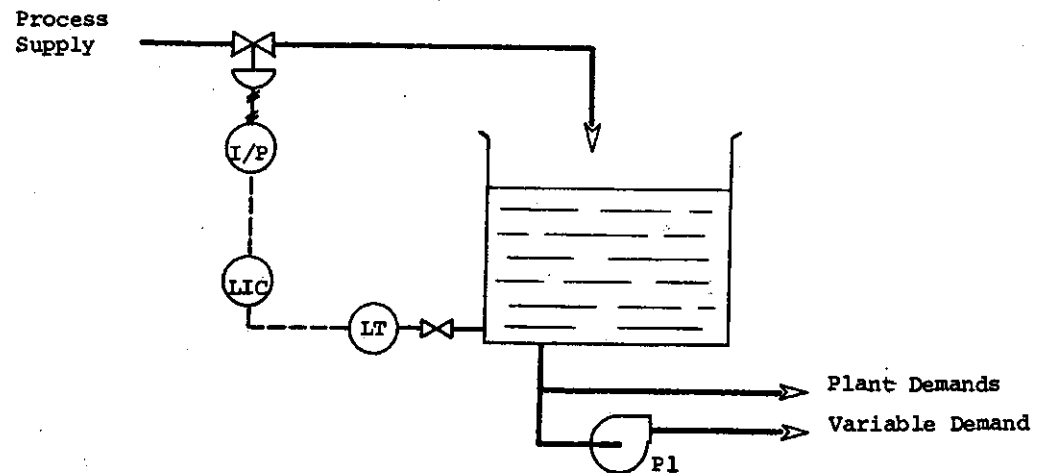

Figure 1: A Level Control System.

Level Response

- This response demonstrates the typical action of a negative feedback control system.
- The error must appear *before* a control correction can be made.
- The control system is always acting after the fact to restore the process to the set point.
- The control approach can be modified by *trying* to achieve an *immediate* mass balance between the process inflow and outflow values.
- Place a flow transmitter on the tank outflow line and use this signal as the set point for a conventional flow control loop on the inflow line.

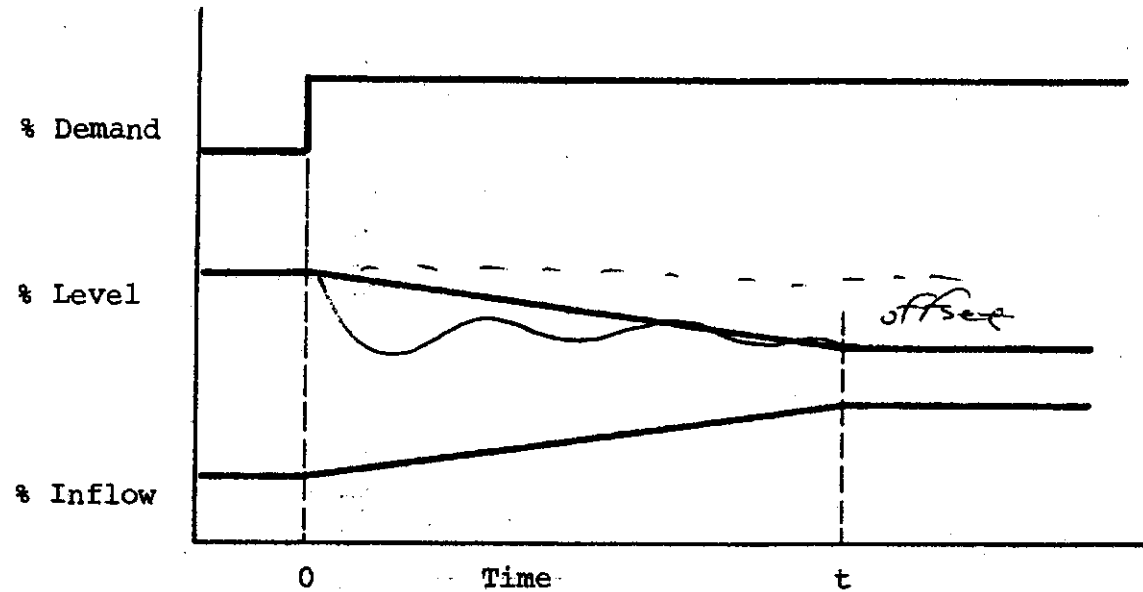

Figure 2: Level Response Following A Disturbance.

Feedforward Level Control

- If the valve selected is air to close (A/C), then the flow controller action must be *direct*.
- The flow controller can be specified with proportional plus integral modes to ensure that the inflow will be driven to that set point value requested by the outflow transmitter (FT2).
- Assume a stable initial control situation with the level at the set point.
- A demand disturbance is applied by activating pump 1 so that the tank outflow is suddenly increased.
- Flow transmitter FT2 will sense the increase in outflow and raise the set point for the flow controller (FIC).
- The flow controller will stroke the valve as necessary to bring the inflow to the requested set point despite supply fluctuation.
- The inflow will match the outflow and the level will not vary (ideally).
- This control response could be depicted graphically as an exact supply correction to *match* the applied demand change which leaves the process undisturbed.

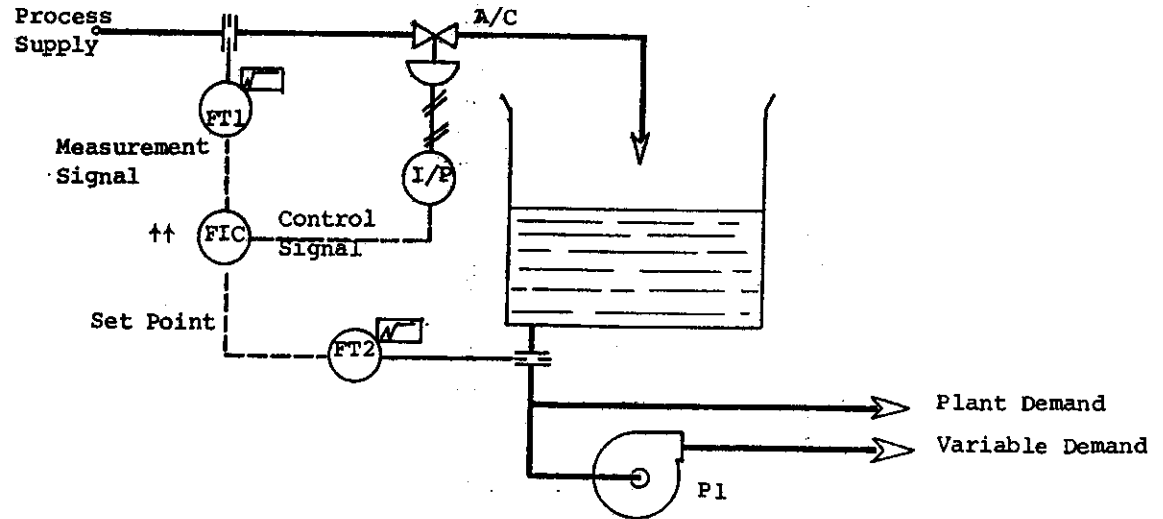

Figure 3: A Feedforward Level Control System.

Feedforward Level Response

The outflow transmitter (FT2) provides a *feedforward* signal so that the process input can be corrected *before* the process is disturbed.

Time Delays

- Visualize the effect on this mass balance control system if there is a time delay between the change in outflow and the corresponding exact correction applied to the supply.
- The level will drop away from the set point uncorrected for the duration of this delay, and then normal regulation will be applied to stabilize the level.

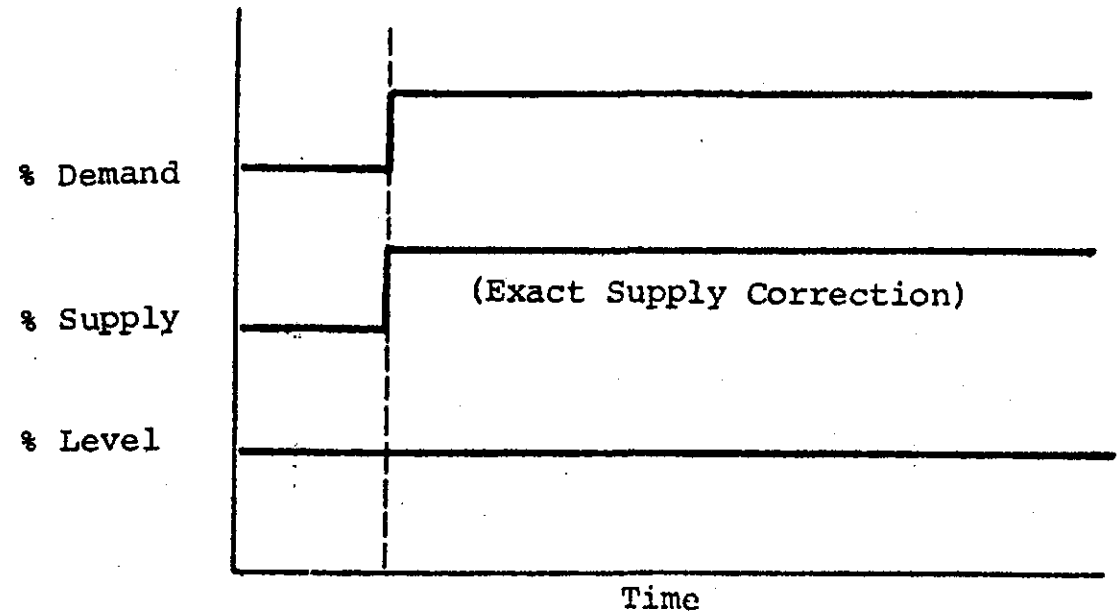

Figure 4: The Feedforward Level Response.

Mass Balance Level Response with A Time Delay

- Note that even an exact supply correction will result in a process deviation if it is delayed in time.
- Process time delays will compound the control problem and result in a lower quality of control in the system.
- Process time delays are caused by three properties of a system:
 1. Capacitance
 2. Resistance
 3. Dead Time

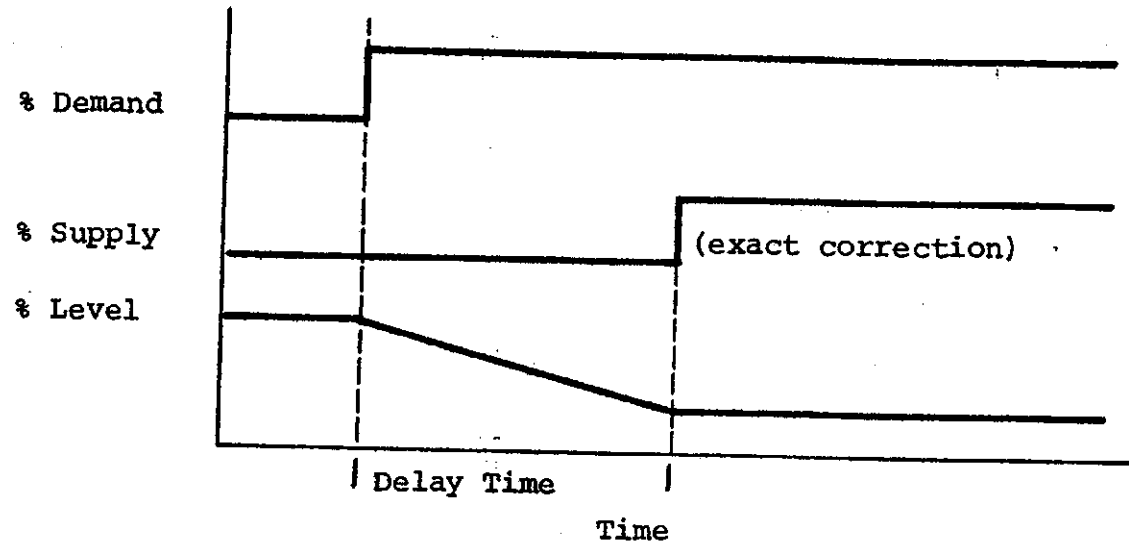

Figure 5: Mass Balance Level Response with A Time Delay.

Capacitance

Capacities of a system are those parts of the process which have the ability to store energy or material. The tank for the level control system has a particular capacity. A distinction can be made between capacity and capacitance. *Capacitance* is the capacity of the system or component per unit quantity of some referenced variable. The simplest example would be level capacitance; the tank capacity wrt the tank level.

Consider two tanks of equal volume (40 m^3), but of different capacitance being controlled over the same level span.

Capacitance of Tank #1: $40 \text{ m}^3 / 10 \text{ m} = 4 \text{ m}^3/\text{m}$

Capacitance of Tank #2: $40 \text{ m}^3 / 2 \text{ m} = 20 \text{ m}^3/\text{m}$

The capacitance of tank #1 is much less than that of tank #2. Tank #1 will show a much larger change in level for a particular inflow change than would tank #2. Tank #1 can be said to have a higher process gain than tank #2; that is tank #1 will have a high gain in units of level per minute. A low capacitance system has a high process gain while a large capacitance system has a low process gain.

Note that *loop gain* can be considered as the product of the controller (k_c), valve (k_v) and process gains (k_p).

$$\text{Loop Gain} = k_c k_v k_p$$

If the process gain (k_p) is very low due to the large system capacitance, the loop gain can be increased by raising the controller gain (narrowing the proportional band). In general if the system capacitance is increased, the proportional band must be narrowed to maintain optimum control.

Resistance

Resistances are those parts of the system which will resist the transfer of energy or materials from one point to another in the system. Connecting pipe or partially open control valves can be considered as resistance elements for the flow of liquid to a tank. The combined effect of supplying a particular capacitance through a resistance produces a time delay in the transfer of energy or material. Such resistance - capacitance (RC) time delays are commonly referred to as *transfer lags*.

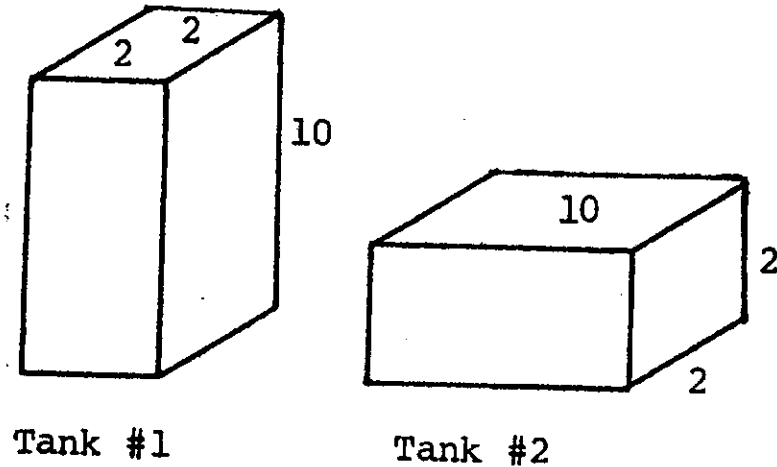

Figure 6: Tanks With Equal Capacity But Different Capacitance.

Dead Time

A third contribution to lags is the time required to carry a change from one point to another in the process.

- A temperature detector located at point "B" will have a delayed indication wrt the measurement made at point "A". (Neglect heat losses along the pipe from "A" to "B").
- The indication delay or *dead time* will depend on the distance from point "A" to "B", and the *flow rate* of the process.
- The dead time can be considered as the interval between an actual process change and the corresponding indication of that change.
- Dead time is sometimes referred to as *transportation lag* since the response is delayed until the change is transported through the system.

Pure dead time will not alter the shape or the magnitude of a process change, it will only delay it in time.

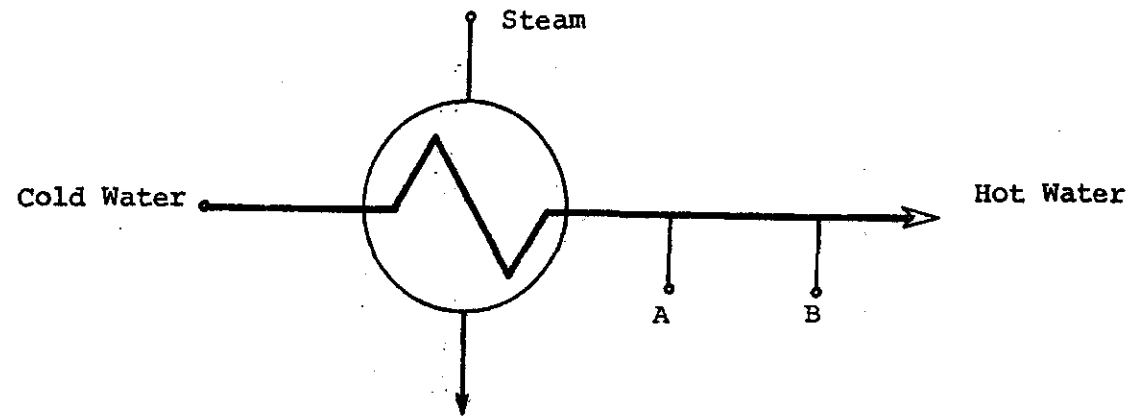

Figure 7: Detector Location Result in a System Dead Time.

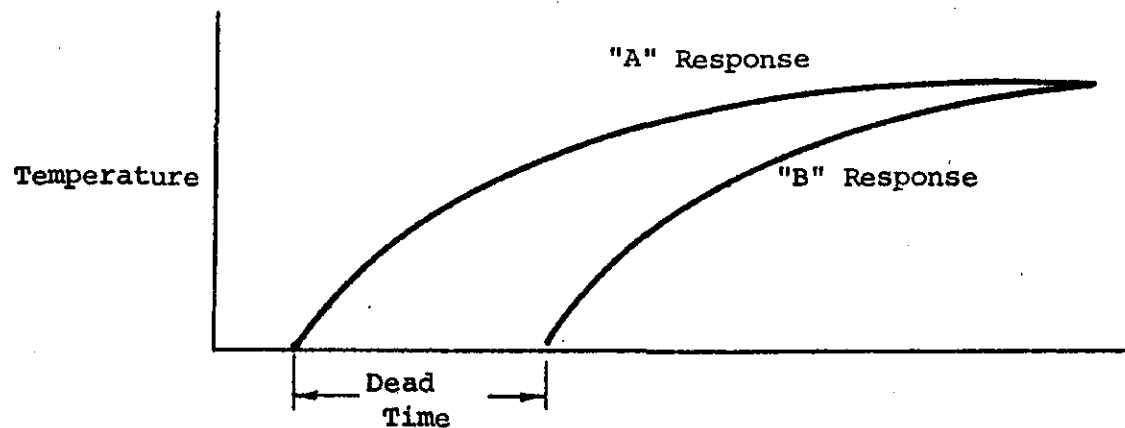

Figure 8: Detector Temperature Response Showing Dead Time.

Dead Time Cycling

- Dead time in a system can produce process cycling if the lag causes the control correction to follow *well after* the disturbance has occurred.
- Consider a simple mixed water temperature control system with a significant dead time component which results from the remote detector location.
- There will be a time delay between the water temperature passing the mixing tee and the detector sensing this temperature.
- Assume that the system is apparently under stable control with a loop gain of one, and that the process is at the set point. A slug of colder water is admitted to the system, causing the mixed water temperature to deviate below the set point.
- When the colder slug is at the temperature detector, the water temperature at *the mixing tee* is back to the desired operating value.
- The controller (TIC) will respond to the decrease in detector temperature by driving the hot water flow valve more open, raising the temperature of the mixed water at the tee *above* the set point.
- This slug of hot water will now pass to the detector when the dead time has elapsed causing the controller to reintroduce a cold slug.
- Since the loop gain was one, the amplitude of the resulting deviations will be constant and the temperature response will smooth out to approximate sinusoidal oscillations.

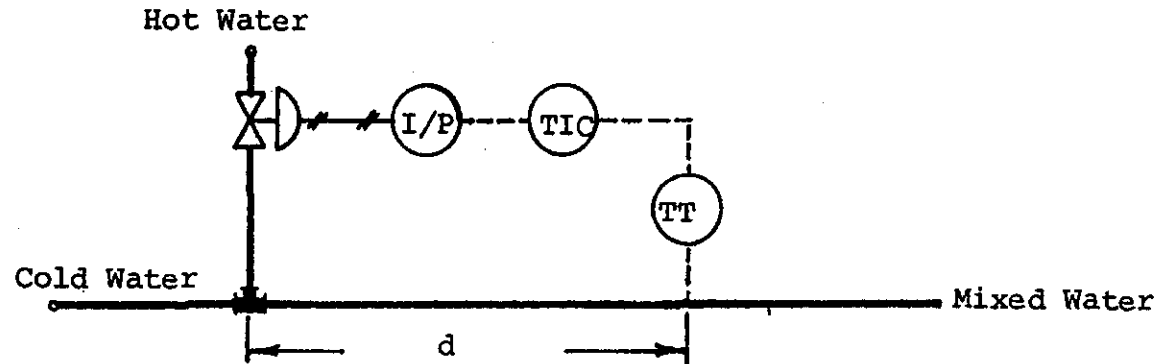

Figure 9: Mixed Water Temperature Control System.

- For any process there will be one specific proportional band setting which will produce a loop gain of one (constant amplitude cycling). This is called the *ultimate proportional band* for that process.
- The adjustment of the proportional band will determine if the disturbance produced cycle will die out or be sustained.
- The operating proportional band in the mixed water system must be *widened* in order to attenuate the process cycling and restore stability.
- In general, the proportional band must be widened if a dead time element is included in the control system.

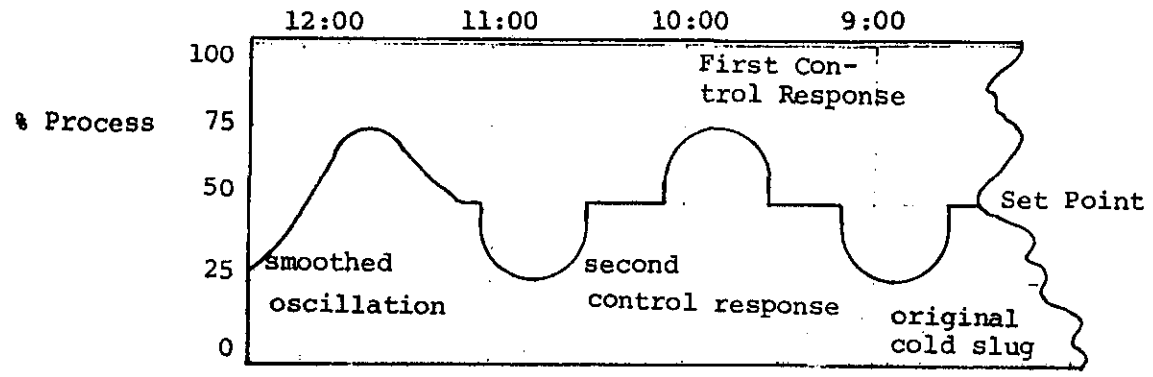

Figure 10: Chart Record of Dead Time Cycling.

Cascade Control Systems

- Cascade control is the interaction of control loops to reduce process deviations and instability by involving more than one controller.
- The output signal of one controller becomes the *set point* for a second controller.
- Cascade control is employed in systems with more than one variable or if there are significant time delays which can effect the desired control objectives.
- If a long time lag exists between a change in the manipulated variable and the resulting effect on the controlled variable, then process cycling can result.

Consider the proportional level control of an open tank as sketched.

- If a demand increase occurs, the level in the tank will begin to drop off. The level controller (LIC) will drive the inflow valve more open until *mass balance* is achieved and the level stops dropping. Say a 5% offset now exists in this system.
- Should an external supply decrease now occur so that the valve is allowing less inflow than expected, the level will begin to drop again.
- This additional error will drive the valve more open until mass balance is again achieved. Say the offset in the system is now 8%. Minimizing this type of deviation following a combined supply and demand disturbance would be desirable. Notice also, that if the system has a very large capacitance, there will be a significant time lag between applying a change to the manipulated variable and the resulting effect on the controlled variable. Cycling as in the dead time example will result.

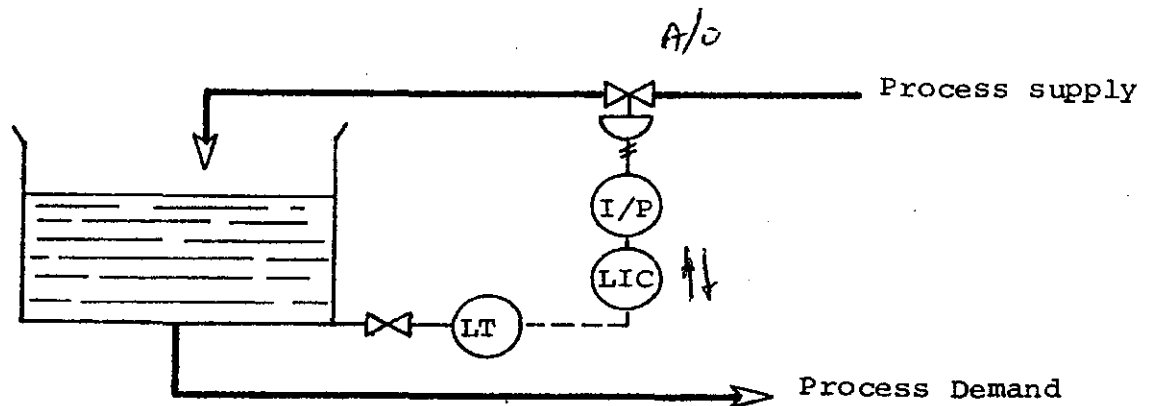

Figure 11: Proportional Level Control System.

General Cascade Control

- The basic cascade approach is to attempt to eliminate disturbances before they reach the large capacitance, slow responding system.
- In this specific case, level control was adequate if only a demand change was applied and the supply was constant.
- The solution is to essentially make the flow that reaches the tank as constant as possible.
- A flow control loop is required to smooth supply fluctuations and to prevent the fast responding flow system from disturbing the slower responding level system.
- The general format for a cascade control system is to have the control signal from the major lag controller applied as the set point to the minor lag controller.
- The major lag controller which develops the set point signal is referred to as the *primary* controller.
- The minor lag controller which accepts the set point signal is the *secondary* controller.

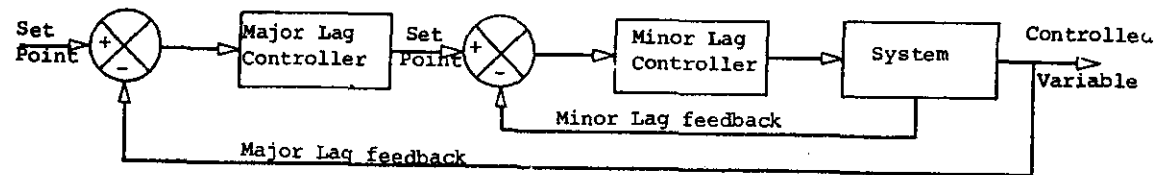

Figure 12: General Cascade Control.

The level system can be adapted to provide cascade control with a primary level controller and a secondary flow controller.

Cascade Level Control

- The secondary controller action can be determined in the normal fashion by considering the desired valve motion.
- For example, if the flow rate is too high, the valve must close or the control signal must be reduced. The flow controller must have reverse action ($\downarrow\downarrow$).
- The primary controller action can be determined by considering the overall desired response of the system. Should the tank level be too high, the inflow must be reduced. The set point for the flow controller should be lowered. (e.g., change the inflow from 65% to 55%.) The primary controller action in this case must also be reverse action.
- Imagine an increased demand disturbance being applied to this cascade control system. The level in the tank will begin to drop away from the set point. The level control signal from the LIC will increase proportional to the error, raising the set point for the flow controller (FIC). Inflow to the tank is increased in accordance with the set point change until a mass balance is achieved and the level stops dropping.
- If an external supply decrease now occurs, the secondary controller will sense the flow variation and manipulate the valve position *until* the flow rate is restored to the requested set point. The flow controller will regulate the flow to prevent supply fluctuations from affecting the level system.

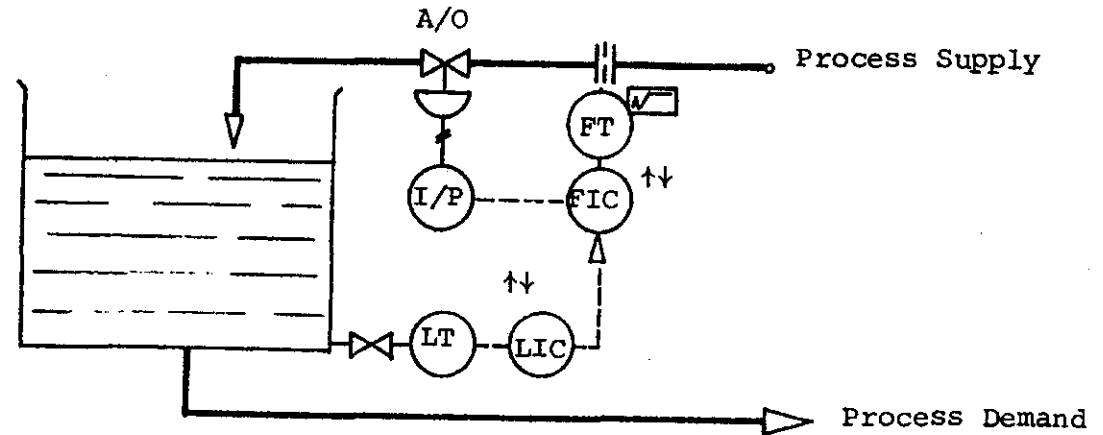

Figure 13: A Cascade Level Control System.

Problem

Sketch a cascade control system used to regulate the hot water effluent temperature from a heat exchanger. Steam flow to the HX provides the energy input to warm the cold water. The temperature of the cold water and the steam supply pressure can fluctuate. The hot water flow must be able to swing with demand changes so that the control valve is located on the steam line. The valve must fail closed in the event of lost instrument air. Determine the major and minor lags, state controller actions, and briefly describe one cycle of operation following a decrease in hot water demand.

The cascade control approach will still perform as a negative feedback loop; an error must occur in the process before the control correction can be applied. The control system will then act in opposition to this error in an attempt to restore the process to the set point. Closer control of such a system may be possible by including a *feedforward* component in the control system.

The problem with the feedforward system introduced earlier in the module (Figure 3) was that the level could wander away from the set point due to process or control system time delays. A level controller could be included in the control scheme to ensure that the level is maintained at the set point. The feedforward element is required to minimize the process deviation following a demand change when there is an inflow/outflow mismatch. An outflow transmitter (*feedforward*) signal can be combined with the level control signal and the resulting signal can be applied as the set point for the inflow controller.

If the level is at the set point, the control error is zero and the proportional controller will develop a 50% signal (12 mA). This controller (LIC) will be reverse acting so that if - the level is too high, the set point for the flow controller will be reduced. The outflow transmitter signal and the level control signal can be combined with a *summing amplifier*.

A flow set point change is not required by the level controller if the tank level is at the set point. Consequently, the summing amplifier can be adjusted so that a level control signal of 50% (zero error) will be ignored. This can be accomplished by setting a constant negative 50% signal or *bias value* on the amplifier. The summing amplifier will perform the following routine:

$$(\% \text{ LIC signal}) + (\% \text{ FT2 signal}) - (50\% \text{ bias}) = \text{summed signal}$$

The signal from the summing amplifier is applied as the set point for the inflow controller (FIC).

Assume that the level is at the set point, then the LIC will develop a 50% control signal which will just equal the applied bias value. The set point for the FIC will equal the signal from the outflow transmitter (FT2). The flow controller will now regulate the inflow to the tank wrt the requested set point (FT2 signal) despite supply fluctuations. A mass balance will be achieved with inflow matching outflow so that the level is unchanged.

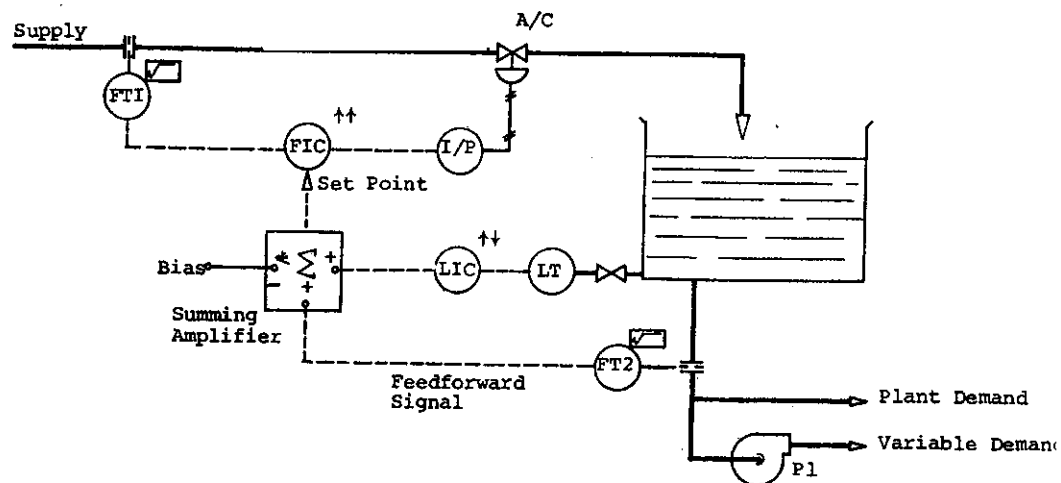

Figure 14: A Feedforward Cascade Control System.

Should a demand increase now occur, raising the outflow, the tank level will begin to drop until the feedforward signal causes the flow controller to restore the system to equilibrium and the inflow again matches the outflow. A level error now exists so that the level control signal will be increased. This additional signal above the bias value will raise the flow controller set point causing the inflow to be greater than the outflow. Notice that there will not be a mass balance condition as long as the level is not at the set point. When the level reaches the set point, the inflow set point will equal the outflow rate so that a mass balance is achieved with zero error in the level system.

This control system should minimize process deviations following a demand disturbance, and the level can be restored to the set point in a stable fashion.

ASSIGNMENT

- 1. Explain the fundamental difference in control response for a feedback and a feedforward control system.**
- 2. Show how an exact control correction will allow a process deviation if the correction is delayed in time.**
- 3. Show how two tanks of equal capacity, controlled over the same level span can have widely differing process gains. Explain which tank will be controlled with a narrower proportional band.**
- 4. Explain briefly to show how a process dead time can result in process cycling. What adjustment should be made in the operating %PB if dead time is included in the system?**
- 5. Define the term "ultimate proportional band".**
- 6. Show the general format for a cascade control system, identifying the major and minor lag controllers.**