

General Digital Control Program Concepts

This lesson provides an introduction to digital control program concepts using the CANDU Moderator Temperature Control (MTC) application as an example.

At the end of the program review, some assessment of performance under Loss of Class IV Power + LOCA conditions will be completed to provide a better insight into the program operation characteristics.

System Description

- The Moderator is the **heavy water D₂O inventory** (used to slow the fission neutrons to thermal energy levels) inside the calandria which is circulated by a main pump through a heat exchanger before being returned to the calandria (so this is a closed system).
- The moderator D₂O fluid is warmed to about 61 C at the moderator outlet by fission process heat and must be cooled by the control of recirculated cooling water flow through the heat exchanger.
- The heat exchanger outlet temperature (calandria inlet temperature) is approximately 35 C at full power so the moderator D₂O can be expected to rise by about 26 C as it is transported through the calandria.

Assignment

Make a simple process sketch of this system to show the Moderator Temperature Control System. You need only show one pump and one heat exchanger - label the direction of flow for the moderator inventory. You should also label both the calandria outlet and calandria inlet temperature points along with a representative large and small temperature control valve which regulates the low pressure service water flow to the heat exchanger.

MTC Program Description

- The function of the Moderator Temperature Control (MTC) program is to control the *temperature* of the moderator heavy water (D₂O) at the calandria outlet to a selected setpoint (usually 61 C at power).
- The MTC is a switched critical computer task which runs every 2 seconds.
- This control program will read the *calandria inlet* and *calandria outlet temperature* signals and use the *signal selection routines* to calculate a *working* calandria outlet temperature parameter (T_{mo}) and a *working* calandria inlet temperature parameter (T_{min}) for control sensing purposes.
- The normal at power operation setpoint ($SET_{T_{mo}}$) is 61 C but the operator has the option of changing this setpoint via the operator keyboard.
- During *start-up operations*, the moderator temperature setpoint would be gradually raised from say 20 C (cold shutdown state) to 61 C (the full power operating temperature) in small increments (so as to allow thermal stabilization) via manual keyboard entry commands.
- The actual temperature control is achieved by modulating *six temperature control valves* (i.e. there are three valves per heat exchanger; TCV13#1/#2/#3, and TCV14#1/#2/#3) which regulate the flow of the low pressure service water flow to the two large moderator heat exchangers (each rated at *50% FP capacity*).
- There are *two large valves* (for example TCV-#1/#2) working in parallel and *one small valve* (TCV-#3 say adequate for 40% FP, season dependent) for each heat exchanger.

MTC Program Description..continued

- The control scheme is a *cascade control* method utilizing *moderator heat exchanger outlet temperature* (i.e. the calandria inlet temperature), the *calandria outlet temperature* and a *feed-forward* term based on *linear reactor neutronic power*.

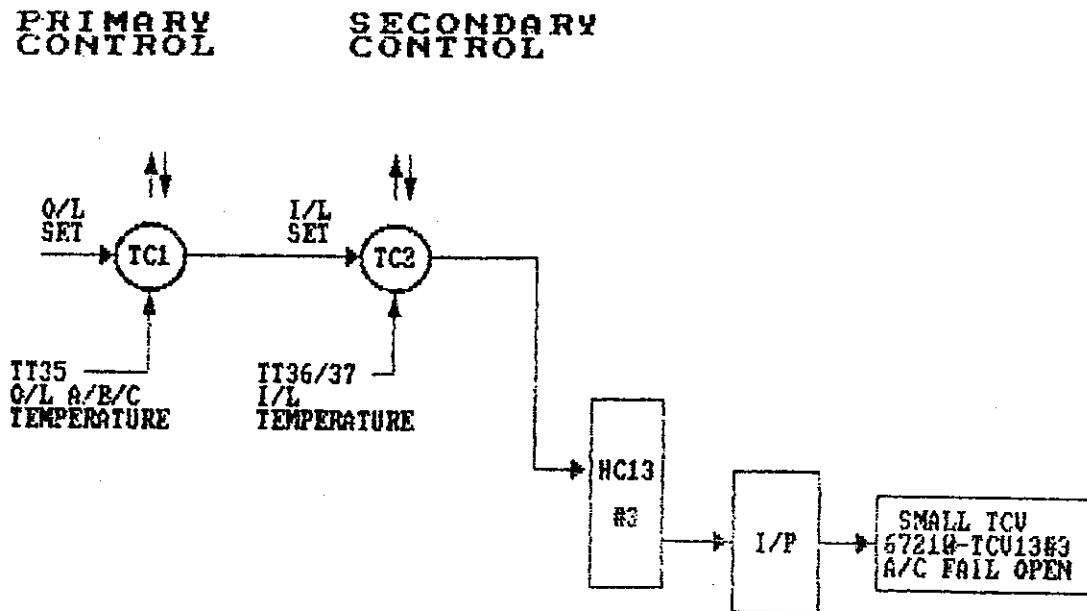

Figure #1 The Cascade Control Configuration for Moderator Temperature Control

- For normal operation, the calandria outlet temperature is controlled to the setpoint temperature of 61 C by the operation of the six temperature control valves which control the flow of cooling water to the two heat exchangers. The setpoint value can be changed at any time by the operator via the setpoint display for MTC.
- On loss of *Class IV power* (the regular power supply to the plant equipment), the service water supplies are interrupted by the loss of pumps and then the recovery *electrical load is reduced or shed* (i.e. this is accomplished by closing the large TCV's to reduce the service water pump load).
- Class III power will be established (from *standby generators*) and service water flow to the heat exchangers will be available after 180 - 240 seconds at a reduced rate.
- The only other control program that MTC interfaces with is the *Reactor Regulating System* (i.e. RRS) from which the Linear Reactor Power (*Plin*) is obtained.

Moderator Outlet Temperature Selection

- The moderator *outlet temperature* is measured by three RTD's (63210-TT35A/B/C) each of which has a range of 0-100 C.
- If all of these temperature signals are *rational* (i.e. within preset signal voltage limits) then the *median* signal is selected (i.e. reject the high and reject the low signal) for control purposes as T_{mo} .
- Actually, prior to selecting the median signal for control, the three rational signals are also checked for *validity* against each other and if they are all within 3 C of each other, then the median signal is still selected.
- However, if only two signals are within 3 C, then the *drifted* signal is alarmed and the *highest valid* temperature is selected as T_{mo} .
- If none of the three rational signals are within 3 C of each other, then this condition (i.e. not validated) is annunciated and the median rational signal is still selected as T_{mo} .
- If one of the three calandria outlet signals is not rational then that signal is *rejected* and the condition is annunciated. The remaining two signals are checked for validity to see if they are within 3 C of each other.

Moderator Outlet Temperature Selection....continued

- The **highest** of these two rational signals is selected for control sensing regardless of the validity check decision, although an alarm would be annunciated to advise the operator that the MTC Calandria outlet temperature measurement has **not been validated**.
- Note that selecting the highest temperature is a **conservative action** since the reactor would be **setback** (i.e. initiate a forced power reduction) or tripped if the moderator becomes too warm.
- If only one of the three calandria outlet temperatures is rational, then that rational signal is selected for control sensing purposes while the other two signals are rejected and their irrational condition is annunciated.
- If none of the three calandria outlet temperatures is rational, all three signals are annunciated as irrational and the MTC program can not satisfy the conditions for continued operation and the program is **failed-off** (i.e. the program stops running in that computer).

Assignment:

1. Prepare a **flow chart** to illustrate the logic needed for the calandria outlet temperature signal selection as described above.
2. Comment on the **apparent usefulness** of the validity checks for this control application - what is the significance of these checks to the overall control program performance.

Moderator Inlet Temperature Selection

- The calandria inlet temperature (T_{\min}) is measured over a **0-100 C** range by two RTD's (63210-TT36/37) with one RTD located at each outlet of the two moderator heat exchangers (i.e. one RTD per HX outlet).
- If both signals are rational (i.e. within preset voltage limits), then the *average* of the two signals is prepared for use as the T_{\min} control sensing parameter.
- If these inlet temperature signals are not within 5 C of each other, then the calandria inlet temperature signals are annunciated as *drifted* (note that we do not know which one is wrong, just that there is poor agreement), but the average is still used for control sensing purposes.
- If one calandria inlet temperature signal is irrational, then it is *rejected* from selection and annunciated as *irrational*. The rational temperature signal is selected for *control sensing* as T_{\min} .
- If both calandria inlet temperature signals are *irrational*, then they are rejected and annunciated. Under these conditions, the MTC program can not satisfy the conditions for continued operation and so the program will *fail-off* in the master computer.
- However, if these signals are still irrational when sensed by the *standby computer* (i.e. perhaps the irrational problem could have been with the input subsystem for the previous master computer and so the problem may have been eliminated by transferring to the standby computer), then a *default* or *expected* calandria inlet temperature value is assigned as a function of the reactor power (i.e. 60.85 C at 0 %FP to 35 C at 100 %FP).
- This *default inlet temperature value* will allow the MTC program to continue to operate on the previous standby computer with *full measurement and control of the moderator outlet temperature* (i.e. the key parameter of concern).
- The preset inlet temperature value (i.e. not live) allows continued operation at power while maintenance can be initiated on the inlet temperature sensing circuits.

Moderator Inlet Temperature Controlcontinued

- The expected calandria inlet temperature or *Feedforward* temperature T_{FD} presents an *expected temperature rise* of 26 C from Calandria inlet to Calandria outlet temperature when operating at full power

T_{FD} is calculated as:

$DT = 0.15 + (26.0 * P_{lin})$ where P_{lin} is the normalized linear reactor power and

$TFD = SET_{Tmo} - DT$

$DT = F1 + F2 * PLIN$

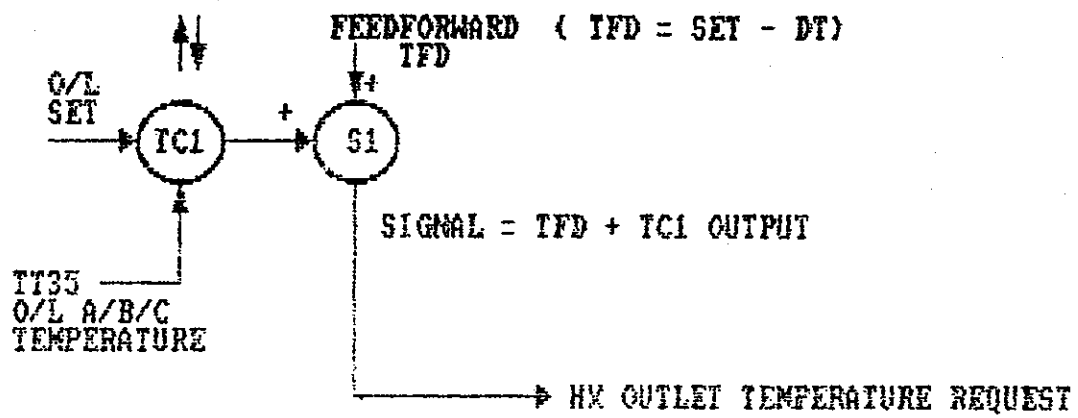

Figure #2 Moderator Inlet Temperature Setpoint Signal Conditioning

Moderator Inlet Temperature Control Loop Features

- The moderator inlet temperature loop controls the heat exchanger (*HX*) outlet temperature (or moderator inlet temperature) by manipulating the flow of the low pressure service water (*LPSW*) through the HX.
- The HX outlet temperature is sensed by *duplicated* temperature transmitters (i.e. TT36/37) which provide a 4-20 mA signal proportional to 0-100 C.
- The LPSW flow is controlled by an air-to-close (i.e. the small TCV's will be used as the example for discussion purposes) *fail-open* valve (TCV13#3).
- Inlet Temperature controller TC2 (i.e. *Secondary* I/L Temperature Controller) compares the HX outlet temperature to the *calculated* setpoint $SET_{T_{mi}}$ and develops a control signal to drive TCV13#3.
- Note that if the temperature is above the setpoint of TC2, that TCV13#3 must be requested to open more to provide more cooling. In order to open TCV13#3 the valve control signal must be decreased since TCV13#3 is an air-to-close valve. Thus TC2 must be a *reverse acting controller* (*increase* in measurement, *decrease* in control signal).
- Calandria Inlet Temperature Controller TC2 will throttle TCV13#3 as required to manipulate the LPSW flow in an attempt to maintain or restore the HX outlet temperature to the setpoint value.
- The temperature error should be calculated in the following manner:
 $T_{err} = SET_{T_{mi}} - T_{min}$
 To give the *correct error sign* (the error is *negative* once the temperature rises above the setpoint). Note that $SET_{T_{mi}}$ is obtained from the control signal developed by the primary controller TC1.

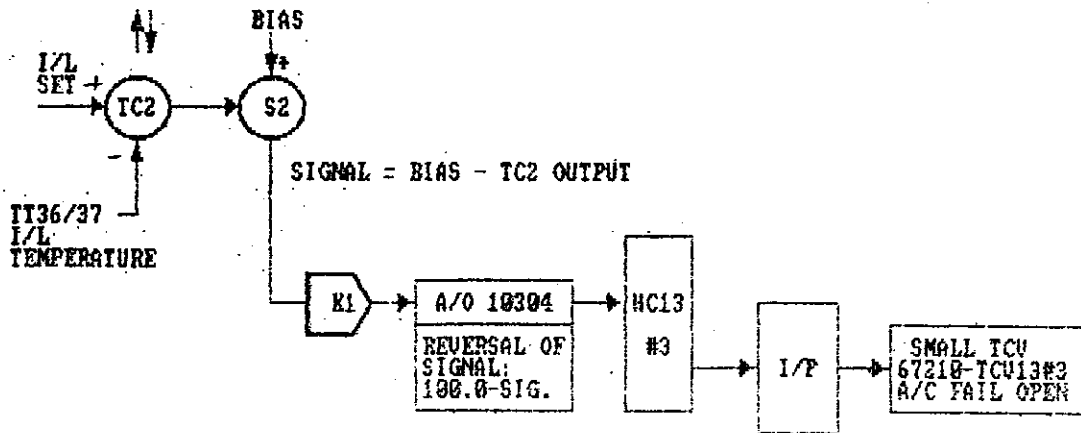

Figure #3 Moderator Inlet Temperature Control Loop Logic

Moderator Outlet Temperature Control Loop

- The moderator outlet temperature is sensed by *triplicated* temperature transmitters (TT35 A/B/C).
- The Moderator outlet temperature loop (TC1 - the *primary* control loop) controls the moderator outlet temperature by requesting colder or hotter inlet temperature setpoint values for TC2 (i.e. the *control signal* from TC1 becomes the *setpoint* $SET_{T_{mi}}$ value for TC2) .
- The moderator outlet temperature controller (TC1) senses the moderator outlet temperature with respect to the TC1 setpoint of 61 C. If the moderator temperature is above the setpoint, TC1 must respond by asking for a lower inlet temperature. Therefore, TC1 must be a reverse acting controller (*increasing* measurement, *decreasing* control signal).
- For example, if the moderator temperature is above the moderator outlet temperature setpoint ($SET_{T_{mo}}$) of 61 C, then the moderator outlet loop controller will request a colder inlet temperature in an attempt to drive moderator outlet temperature back down toward the setpoint.
- This type of control is called *cascade control* with the *major lag* process (i.e. moderator outlet temperature) dictating the *setpoint* for the *minor lag* process (i.e. moderator inlet temperature).
- TC1 is the *primary* (or Master) controller while TC2 is the *secondary* (or Slave) controller
- If a moderator outlet temperature change occurred, TC1 will sense this temperature error with respect to the 61 C setpoint and will develop a control signal change which is the setpoint for TC2. TC2 will respond to the new error that had been created by changing the setpoint for the moderator inlet temperature loop. TCV13#3 will be driven by the TC2 control signal to try to match the HX inlet temperature to the new setpoint for TC2.
- Note also that if the moderator outlet temperature was stable at the setpoint when a disturbance occurred at the heat exchanger outlet temperature (i.e. the moderator inlet temperature), then loop TC2 can act to correct this disturbance *before the moderator outlet temperature is significantly disturbed* so as to minimize any moderator outlet temperature changes.

Moderator Outlet Temperature Loop Operation

- Assume that the moderator outlet temperature was at the setpoint with the small TCV steady at 40% open position when some disturbance occurs which slightly increases the moderator outlet temperature.
- The temperature indicated by TT35 A/B/C will increase above the setpoint for TC1 which will cause a corresponding decrease in control signal which lowers the setpoint for TC2 so that a lower HX outlet temperature is requested.
- The control signal from TC2 will decrease so that the control valve is driven more open increasing the cooling water flow to the HX.
- The cooler HX outlet flow which is the inlet to the moderator should lower the moderator outlet temperature back toward the setpoint.
- However, a *summing function* is provided with the outlet signal from TC1 to alter the setpoint request to TC2. This node allows a *feedforward term* to be introduced by subtracting the differential temperature value (i.e. DT) from the 0-100.0 control signal value developed by TC1.
- This feedforward term is $DT = F1 + F2 * Plin$. With $F1 = 0.15$ and $F2 = 25.85$ so that at 100%FP (i.e. $Plin = 1.0$), DT will be equal to 26.0.
- This feature provides a factor which attempts to *predict the temperature rise* in the moderator from moderator inlet (HX outlet temperature) to moderator outlet.
- Note that there is expected to be very little temperature rise at *zero power* (0.15 C) but at *full power* the moderator inventory temperature will rise 26 C (i.e. inlet temperature of 35 C gives an outlet temperature of 61 C).

Moderator Outlet Temperature Loop Operation.....continued

- So now consider the loop response to a moderator outlet temperature *decrease* while the reactor is held at a constant power level (i.e. Plin does not change). Signal values from TT35A/B/C will drop below the setpoint for TC1.
- Reverse acting TC1 output signal will increase which now subtracts the *unchanged DT* value so that the requested setpoint signal for TC2 has *increased*.
- The *increase in setpoint* to TC2 *looks like a decrease in temperature* and so the reverse acting TC2 will *increase the control signal* output.
- Increasing the control signal will drive the TCV more closed and so will *decrease the coolant flow* to the heat exchanger which in-turn will result in a *higher calandria inlet temperature*.
- The *warmer inlet flow* will tend to raise the moderator outlet temperature back toward the setpoint to *correct the original negative temperature error* condition.

Calandria Inlet Temperature Loop Operation - Bias & Signal Reversal, small TCV

- Assume that the temperature was steady at the setpoint with the small TCV about 50% open when some disturbance is applied to slightly increase the HX outlet temperature.
- Then the TT36 and TT37 temperature will increase above that for the setpoint for TC2.
- TC2 responds by decreasing the control signal output which is subtracted from a *bias* value.
- The bias is an immediate *estimate of necessary final valve position* as a function of reactor power to act in a *feedforward* manner to quickly position the TCV independent of previous control decision values. Then proportional plus reset modes can act to bring the valve to a more correct final position.

Calandria Inlet Temperature Loop Operation...continued

- The (Bias - TC2) signal is a **larger number** (since TC2 signal was **decreased**). A separate gain value (i.e. 2.5) is applied to this control signal to drive the small valve fully open with a 40% change in signal.
- The amplified signal value is now **reversed** by the function ($N_{sig} = 100.0 - Sig$) so that the final signal output will decrease so the signal to the valve is reduced.
- The **reduced signal** to the air-to-close valve allows the **valve to open more** so the LPSW flow to the HX is increased to provide more cooling effect. Note that if the instrument **air supply is lost**, that TCV13#3 will fail open (i.e. it is an air-to-close valve)

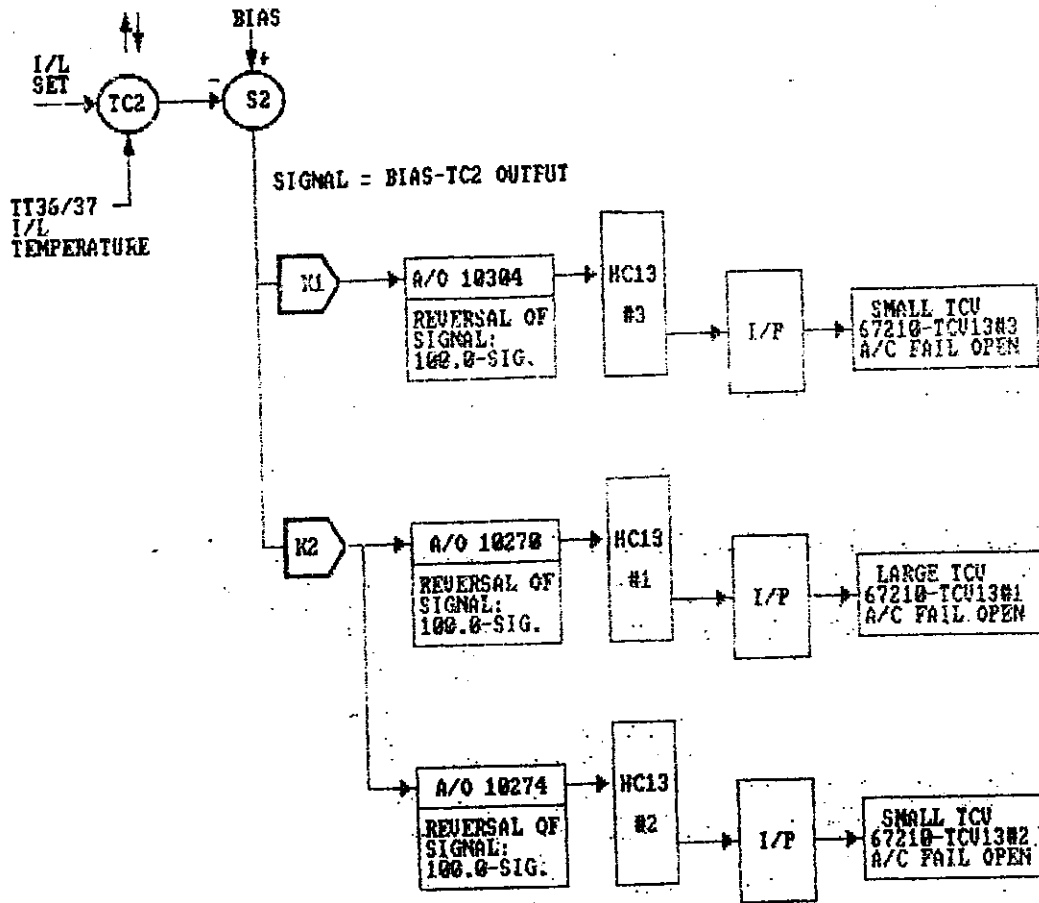

Figure #4 Moderator Inlet Temperature Control Loop – Final Valve Interfacing

Calandria Inlet Temperature Loop Operation - All TCV's

- The complete loop logic now involves the moderator inlet temperature TC2 which compares the temperatures from TT36 & TT37 against the *computed setpoint* which is cascaded from TC1.
- The output signal from TC2 is subtracted from a *feedforward bias* which attempts to set the valves roughly as a function of reactor power.
- This signal now has a gain of 2.5 applied to it for the small TCV or a combined gain which begins to stroke the large valve open as the lift changes from approximately 30% (i.e. when the small valve reaches 75% open).
- The large TCV's have a function applied which is $((LIFT - K2)/K3)$ so that the large valves start to open with a 30% signal lift (i.e. $K2 = 0.3$ and $K3 = 0.7$) and drive completely open with a 100% lift signal.
- The signal is *reversed* (i.e. 100.0-Sig) before being output to drive the air-to-close valves in the correct direction and the valves will fail open for a loss in electrical signal or a loss in pneumatic signal.

MTC Response to CLASS IV Loss + LOCA

- Problem: Moderator over-cooling from 100% FP with only loss of Class IV and potential warming of moderator on incore LOCA condition.

Original Logic Description - following a LOCA+ Loss of CL IV

- Following a loss of Class IV + LOCA, the MTC BIAS would be set to 0.8 (i.e. 80% FP) which will drive the small TCV's 100% open and the large TCVs 75 % open.
- If the reactor was tripped from 100% FP, the net change in moderator cooling would be very small while reactor power is high.
- Full cooling flow capability would only be provided once the Class III/IV power is restored (say after 180 seconds when the Standby Generators have run up to power and have picked up the load) and by then the reactor has tripped and power has run down to about 5% FP (thermal) conditions.
- Under these conditions, the TCV's would slowly be driven closed as the calandria outlet temperatures dropped. When the calandria outlet temperature drops 3.33 C, the setpoint for the inlet loop will be lowered by 5C (due to the O/L loop gain of 1.5 applied) but can not be lowered any further as there is a 5 C limit applied to this setpoint request.
- The inlet loop will respond to this setpoint change with a proportional control signal change of 12.5% (I/L loop gain of 5) (which in-turn is a 15% lift for the large TCVs.
- As the outlet temperature drops, the load on the moderator heat exchangers will decrease causing the heat exchanger outlet temperature to also drop.
- As the inlet temperature decreases, the TCV lift will decrease, closing in the TCVs.
- Beyond this proportional response, the inlet loop control reset action would have to provide the remaining valve lift signal change to close the TCV's.
- If the reactor was tripped, then the MTC lift signal would have to change from 0.8 to 0.1 in order to close the large TCV's and set the small TCV's to 25% open (assuming no LOCA to the moderator). This signal change of 70% would require 4.6 repeats of the original proportional response of 12.5%.
- With the present reset time setting of 285 seconds, nearly 22 minutes would be required to close the TCV's (i.e. overcooling for more than 20 minutes).

Original Logic Description - following a LOCA+ Loss of CL IV

- If this 70% valve position was supplied by **only inlet loop proportional** response to the outlet loop cooling, the outlet temperature would have to decrease by 28 C (this is found by $70\%/2.5 = 28$). **The 30 C moderator temperature** would be obtained by decreasing the moderator temperature from 61 C by the original 3.33 C and then by the further 28 C ($61 - 3.33 - 28 = 30$ C). Actual control with reset should be much better than this, but this gives a worst case response example for comparison purposes.

Commissioning Based Study Design Recommendation

- Upon a loss of Class IV power plus a LOCA, the inlet temperature control loop integral term would now be set to hold the **small TCV's at 45% open** (i.e. lift signal = 0.18) with the **large TCVs closed**.
- The reactor is tripped at the onset of this Class IV power loss so actual reactor power should be about **5% FP (thermal)** within 10 - 20 seconds.
- The reset control mode **integral action is suspended** for 180 seconds or until the Class III/IV power is restored.
- The calandria outlet temperature **setpoint is lowered to 57 C** from 61 C.
- This new 4 C control error (i.e. $61 - 57$) will cause the **maximum limited** proportional response of -5 C for the setpoint of the inlet loop which will increase the valve lift signal from 0.18 to 0.305. (i.e. $5\text{ C} * 2.5 = 12.5\%$, $18\% + 12.5\% = 30.5\%$)
- The small TCV's will then be 76% open (i.e. $0.305 * 2.5 = 0.7625$) and the large TCV's will just be open less than 1% ($1.43 * (\text{Lift} - 0.3)$).
- Note that during this 180 seconds time period the valve positions are not significant as there is **no coolant flow** due to the loss of power to drive the pumps.
- However, cooling equivalent for 45% FP (Lift of 40% = small valves fully open and large valves about 15% open) will be provided **once the Class III/IV power is restored**. Integral action will be restored when the Class III/IV power has been restored.

LOCA Condition, but not In-Core

- The intention of this revised design logic would be to **limit the moderator cooling** to no less than **53 C** once cooling flow is restored to the heat exchanger. (recall the temperature had to be lowered to 30 C in the previous straight proportional response discussion)
- The overcooling problem must be considered for both an **in-core** (i.e. hot inventory leakage from the HTS) and an **out-of-core** LOCA condition (no HTS leakage to moderator).
- If the moderator **outlet temperature begins to fall** (due to the **lower reactor power, restoration of cooling and no LOCA to the moderator**) then the proportional response from the outlet loop can increase the inlet loop temperature setpoint by up to 5 C (actually removing the previously applied -5 C change to the inlet temperature loop setpoint due to the moderator temperature of 61 C with a setpoint of 57 C).
- This setpoint change (increase in requested inlet temperature setpoint) will decrease the TCV lift by 12.5% (under proportional control) back to 0.18 which will **close the large TCVs completely** and drive the **small TCV's to 45% open**.
- If the calandria outlet temperature continues to fall, the TCV lift can be decreased **another 12.5%** on straight proportional action as the outlet temperature drops to 53.6 C (a change of 3.3 C from 57 C since there is a gain of 1.5 applied to the O/L temperature to develop the setpoint value to cause a +5 C I/L setpoint change).
- This change will request a further +5 C setpoint increase for the inlet loop (to reach the +5 C limit) and so the valve lift would be decreased from 0.18 to 0.055.
- The small valves would be stroked to the 14% position ($5.5 * 2.5 = 13.75\%$) which is well below the 25% open position **normally required for ZPH** operation.
- In this way, **proportional only response** should be able to control the moderator outlet **temperature well above 53 C** as soon as the cooling effect of the LPSW is restored. Note that this is an improvement of 23 C over the previous approach where the moderator could be cooled to 30 C. Of course actual control should be much better than this with reset action acting to hold the temperature closer to the requested setpoint and so it is not anticipated that the temperature should drop much below the 57 C value.

LOCA Conditions, In-Core

- If the Calandria outlet temperature **begins to rise** (i.e. since LOCA is into the moderator and **hot HTS inventory** at possibly 265 C is flushing into the moderator fluid), then the proportional response from the outlet loop temperature change will be limited to the previously mentioned -5 C for the inlet loop setpoint value.
- Additional increases in moderator outlet temperatures will have **no further effect** on the inlet loop setpoint. Further control action must come from the **inlet loop proportional and reset** responses.
- When the reactor is tripped, the BIAS term will decrease to the minimum value and the **large TCVs will be closed**. MTC lift will likely be about 10% (based on past experience) and so the **small TCVs will be 25% open**.
- If the moderator outlet temperature is increasing due to the LOCA, the inlet loop will respond to the change in heat exchanger load.
- At LOCA sense time, the moderator outlet loop setpoint would be set to 57 C. This will present a 4 C error from the outlet loop (i.e. 61 C moderator temperature) resulting in an additional lift of ($4 * 1.5 =$ limited to 5) $5 * 2.5 = 12.5\%$ for the TCVs. The small TCV's will now be about **55% open** ($2.5 * 25$) and the large TCVs will be closed.
- For each increase in moderator temperature of 1 C, the inlet temperature rise will cause an inlet loop proportional response of an additional 2.5% valve lift which will in-turn open the small valves an additional 6.25% and the large TCVs by 3.5%.
- In this way (from the initial conditions of small TCVs at 55% and large TCVs closed), if the Moderator temperature increased by about 7 C (i.e. to 68 C), the small valves would be 100% open (i.e. 40% lift) and the large valves would drive to about the 15% open position.
- In order to drive the large valves fully open the calandria temperature would have to increase by about another 24 C (60% lift from 40% to 100%; $60\%/2.5 = 24$ C i.e. $68 + 24 = 92$ C)
- 92 C **does not provide much sub-cooling margin** and so should be reconsidered

Allow a Colder Inlet Temperature to be Controlled

- An improved moderator temperature control (more responsive to the high temperature rise) could be achieved by applying a lower negative limit to the inlet temperature setpoint (say -31 C rather than -5 C); that is, allow the temperature control to continue to be responsive to positive going temperatures rather than be limited).
- This limit would be revised from -5 C to -31 C when the LOCA condition is sensed. If this limit was provided, then the inlet loop temperature setpoint can be lowered by 31 C (i.e. from 61 to 30 C) by the action of the primary temperature controller as the outlet temperature rises by +21 C (i.e with the interloop gain of 1.5).
- Find the moderator outlet temperature needed to drive the TCVs fully open with straight proportional action. If we start with the LOCA setpoint of 57 C, remember that the lift signal was expected to be 40% so that only a 60% valve lift signal needs to be developed. So $60/2.5$ is a 24 C I/L temperature scale change. However, there is a 1.5 gain factor from O/L to I/L so the outlet temperature need only change $24/1.5 = 16$ C. then the temperature need only rise to $57 + 16 = 73$ C to drive the large valves fully open (so maximum cooling is obtained when moderator rises to 73 C). This represents a worst case control of sub-cooling margin improvement of 19 C - from 92 C to 73 C for TCVs full open.
- This moderator inlet temperature setpoint could be limited to 30 C to ensure that excessively low inlet temperatures are not requested.
- Initial TCV position upon LOCA sense would be increased as the original error of 4 C would not be limited (setpoint change was 5 C before, now would be 6 C). The resulting increase in TCV lift signal will provide increased initial cooling over that which would have been provided with the original -5 C limit applied.

The summary of MTC program revisions required would be to:

- 1) **revise the calandria outlet temperature setpoint to 57 C from 61 C**
- 2) **lower the limit on the calandria inlet temperature setpoint to -31C from -5 C.**
Both of these changes to be applied once a LOCA condition is sensed.
- 3) An **additional limit on the inlet temperature setpoint** should be applied to ensure that the inlet temperature setpoint does not decrease below 30 C.

Moderator Temperature Control Assignment

1. Sketch a typical moderator heat exchanger temperature control circuit to show the relation between the calandria inlet temperature and calandria outlet temperature control loops as a cascaded control example. Show and label the key components of the physical system.
2. What are the desired operational restrictions or limitations placed on the moderator temperature that the control system should strive to achieve?
3. What is the planned function or range for the calandria inlet temperature as reactor power is increased from 0% to 100%FP? What is the designed value for calandria outlet temperature over this same power range change?
4. Briefly explain the difference between a software rationality check and a validity check.
5. Briefly explain how the temperature control valve lift signal as a function of reactor power provides an immediate valve correction based on an inferred parameter that is able to quickly place the control valves in the approximately correct energy balance position.
6. Review and summarize the original MTC design logic for the loss of Class IV power plus LOCA condition. Briefly explain why the moderator would be overcooled upon power restoration if the LOCA fluid was not discharged to the moderator.
7. Review and summarize the commissioning proposed design change for MTC to confirm, or not if the overcooling problem identified in question 6 has been corrected. Briefly explain how the overcooling condition would be prevented or the further improvements needed.
8. Review and summarize the commissioning proposed design change for MTC to confirm, or not if adequate cooling is provided to the moderator for the case when the in-core LOCA is discharging hot HTS fluid to the moderator. Briefly explain how adequate cooling is provided.