

Mechanical Equipment - Course 430.1

VACUUM PUMPS

A vacuum is generally considered to be a space, (a vessel, or system) containing air or any other gas at a pressure less than that of the atmosphere. There are several applications of vacuum in our nuclear plants, the major ones being the vacuum building, the condenser, shell side and condenser tube side (where vacuum establishes and perpetuates the syphon) and the finishing unit at the Bruce Heavy Water Plant.

Generally speaking there are two basic methods of producing a vacuum. In the first method gas or vapour molecules are physically removed from the space and exhausted to the atmosphere. This is accomplished by using vacuum pumps. In the second method the physical or chemical state of gas or vapour is changed. Typical methods are heat removal or a chemical reaction. It is within the scope of this course to explain only the first method, ie, to classify vacuum pumps.

Vacuum pumps can be classified into two groups: MECHANICAL and VAPOUR.

Mechanical Vacuum Pumps

The trainee at this point is familiar with operating principles of compressors, blowers and fans. It should not be of any surprise to find out that operating principles of mechanical vacuum pumps are identical to those of other gas handling devices; all of them take a suction from a lower pressure space, pressurize the gas and discharge it to a higher pressure space. The difference is that compressors, blowers and fans take suction from surrounding atmosphere and discharge to a close space or system at higher pressure, while vacuum pumps take a suction from a closed space at lower than atmospheric pressure and discharge to the surrounding atmosphere. Obviously, except for some minor design features, the devices can be and are almost identical.

In the design of mechanical vacuum pumps two principles are utilized: reciprocating or rotary or possibly a combination thereof. Both principles are characteristic of positive displacement devices. There are no dynamic vacuum pumps in existence.

The reciprocating principle is used in piston vacuum pumps. The construction is well known - the piston is moved back and forth by a crankshaft, usually driven by an electric motor. There may be one or more cylinders and pistons driven by a single crankshaft which can be mounted vertically or horizontally. The pistons are generally double-acting and, therefore, both sides of the cylinder must have suction and discharge valves. The application of piston vacuum pumps can be found in the Upgrading Unit (UPP) at Pickering NGS.

Another positive displacement reciprocating pump is a diaphragm pump but it is very seldom used in larger industrial applications.

There are several types of rotary pumps used for vacuum duties, most of which are again similar in general principle and design to rotary pumps used for normal pumping and compressing duties. In all cases there is a rotor which rotates within a hollow cylinder, which forms the body of the pump, the ends of which are closed by suitable plates. Rotary pumps can be dry running, oil drip lubricated or flood lubricated with oil or water. The inner surfaces of lubricated pumps are covered by a liquid film which forms a gas seal as well as cooling the pump.

The type most frequently found in our plants is a positive displacement, rotary, helical lobe, screw-type vacuum pump (Figure 1). They are used to create and maintain the

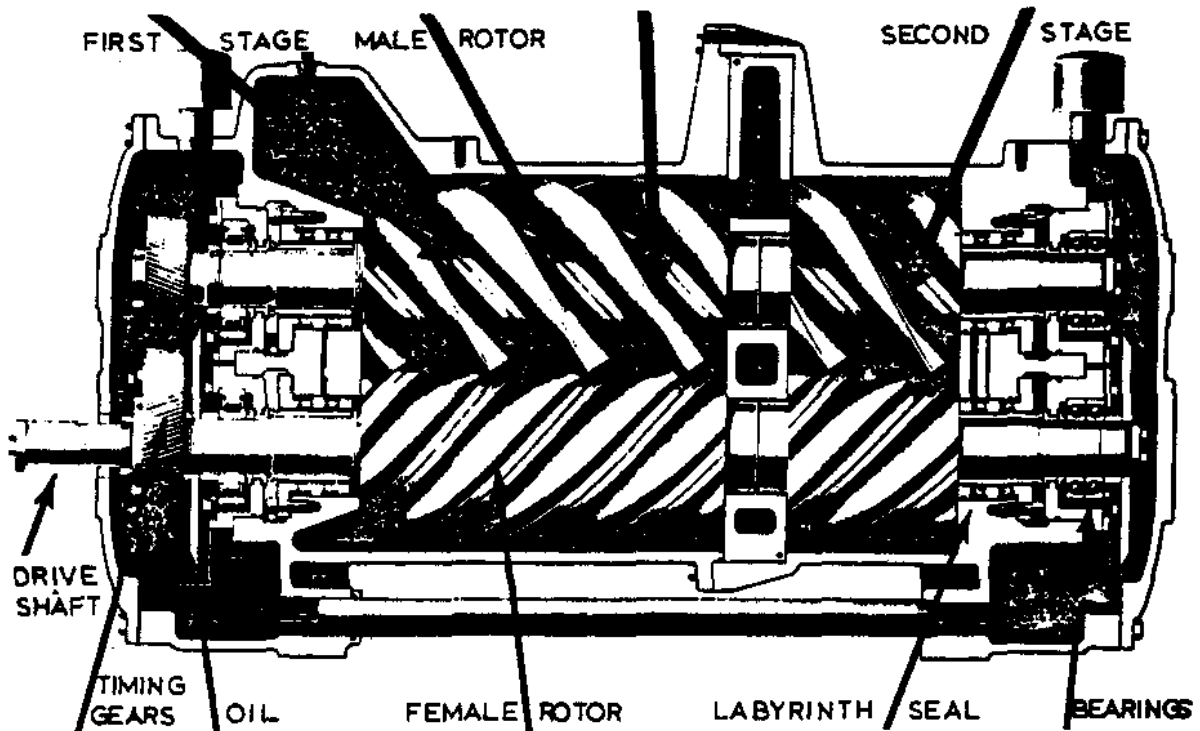

Figure 1

vacuum in the vacuum buildings at Bruce and Pickering NGS. The vacuum maintained there is 6.9 kPa(a) (2 in Hg abs). The same type of pump is also used on the main condenser (shell side) at Pickering NGS.

The displacement is obtained by meshing of two helical rotors on parallel shafts encased in a vertically split housing. Parts for suction and discharge are at opposite ends of the housing, with the inlet part at the driven end. The circular profile rotors are known as male and female rotors (Figure 2). Both are of the same diameter. Power input is

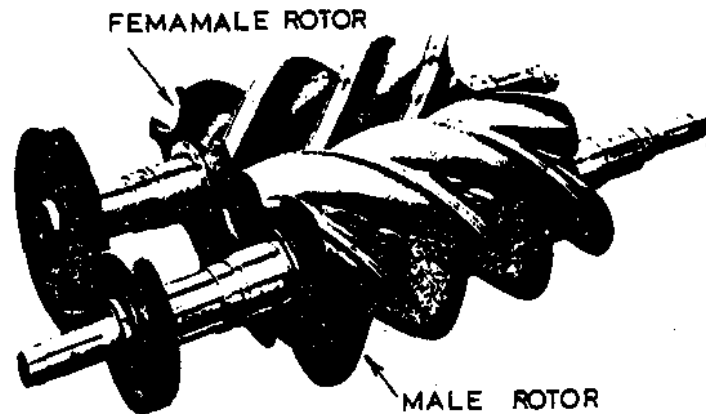

Figure 2

to the female rotor shaft. The torque is transmitted to the male rotor through the timing gears. In our case (pumps in the picture), it is a two-stage pump. These pumps can handle large quantities of air.

Another type of vacuum pump using the rotary principle is a sliding vane pump, (Figure 3). A rotor has diametrical slots which accommodate two or more free sliding vanes. They are held apart by springs that press them onto the surface of the stator. Inside the stator the rotor is mounted eccentrically with one point of it always in contact with the wall of the stator. The oil film between them forms an airtight seal.

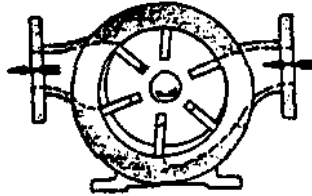

Figure 3

Lobe type vacuum pumps have lobed rotors which are gear driven to rotate at the same speed but in opposite directions and without touching each other. The rotors are enclosed within the casing or stator. As the clearances are from 0.005 to 0.01 inches and there usually is no oil seal, there is a back flow from the discharge to the suction. As there is no rubbing contact, higher speeds of rotation can be used. These vacuum pumps can handle considerable quantities of air which requires substantial cooling in the exhaust region.

The impellers come in a variety of shapes, two, three, four lobes. The two-lobe type, often called Roots, was shown in the lesson on positive displacement compressors. Figure 4 shows a four-lobe type.

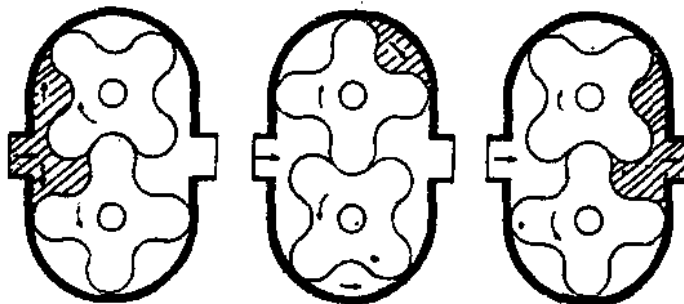

Figure 4

Rotary Air Pump in Figure 5 is a vacuum pump which uses rotary and centrifugal principles and to some extent a reciprocating action.

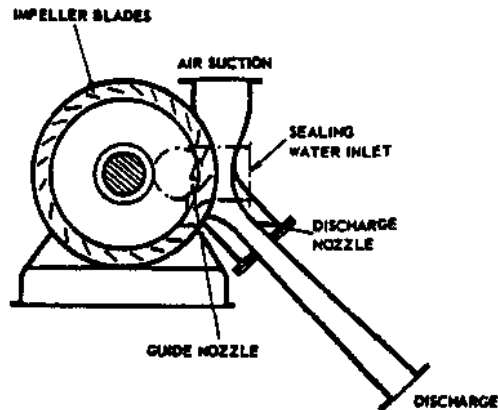

Figure 5

The impeller of the rotary air pump consists of a blanking plate mounted on a pump shaft. The closely spaced blades are attached to the rim of the blanking plate. Sealing water is fed into the pump and is broken into slugs by the impeller blades. These slugs of water pass to the discharge nozzle, draw the air in the effectively seal the pockets of air as they pass through the diffuser. From the diffuser, the air, non-condensable gases, and sealing water are discharged either to the drain or into a tank where water and gases are separated and water reused. The rotary air pump is used at NPD NGS on the main condenser shell side.

Finally there is a vacuum pump which use reciprocating, rotary and centrifugal action. It is called liquid-ring or liquid-piston vacuum pump. Again exactly the same principle is used in compressors. Figure 6 explains the pumping action.

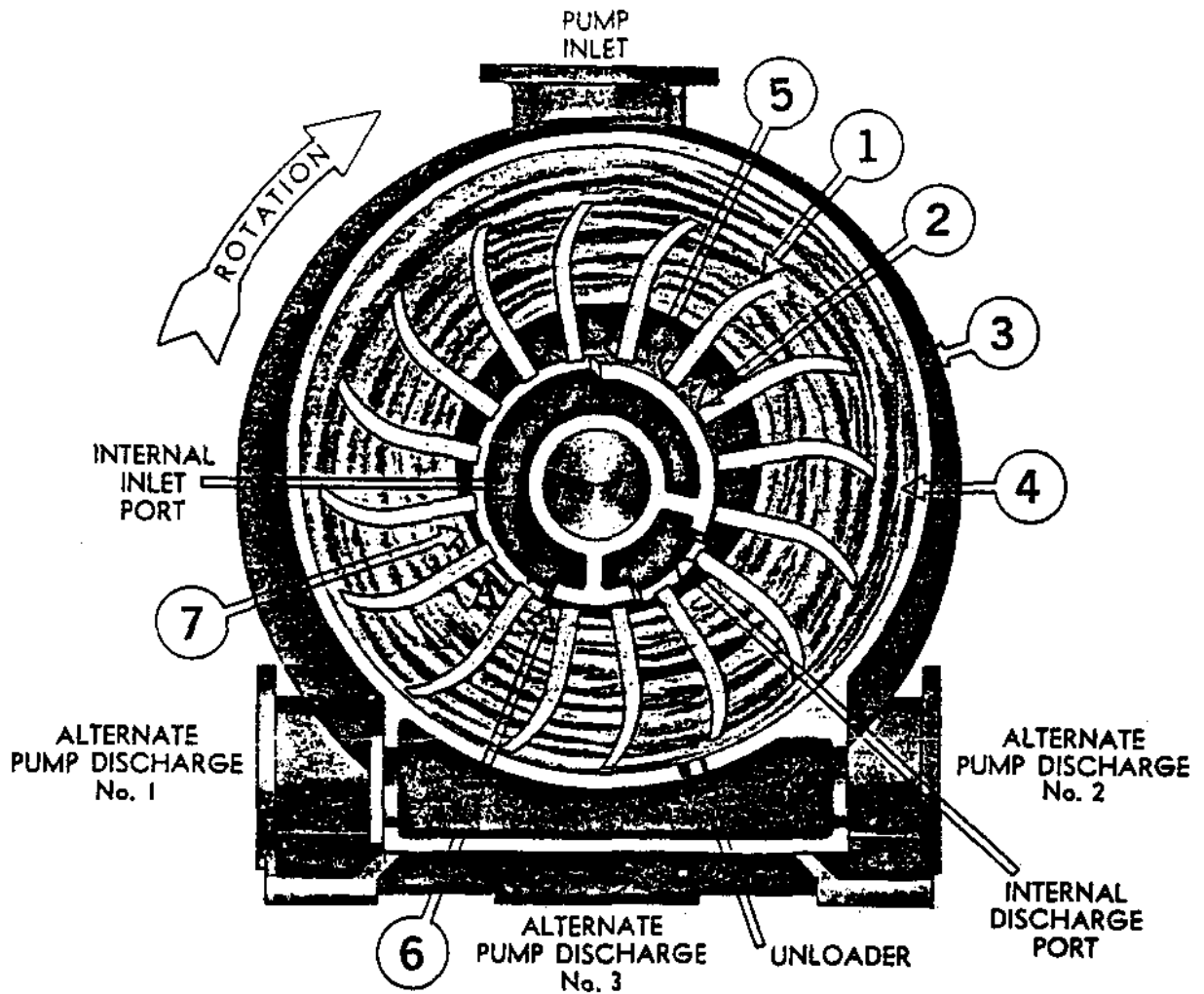

Figure 6

A rotor (1) revolves without metallic contact in a circular casing (3) containing liquid, usually water (4). The rotor is a casting consisting of a series of blades projecting from a hollow cylindrical hub. The blades are shrouded at the sides and form a series of chambers. Note that the curvature of the blades is in the direction of rotation unlike the rotor on centrifugal pumps. Starting at point "A", the chambers of the rotor are full of water. This water rotates with the rotor, but follows the contour of the casing (3), due to centrifugal force. The water (4) which entirely fills the rotor chamber at "A", recedes as the rotor advances until the rotor chamber attains its maximum size at (5). The converging casing forces the water back into the rotor chamber until it is again full at (6). This occurs once in each revolution. As the water is caused to recede from the motor chamber at (7), it is replaced by air drawn in through the inlet port in conical casting (2), connected with the

pump inlet. As the rotor turns 360 degrees and the water is forced by the casing back into the rotor chamber, the air that has filled the chamber is forced through the discharge ports in the conical casting (2) into the pump discharge.

Liquid-ring pumps are used as vacuum priming pumps in CCW Systems (Condenser Cooling Water) for establishment and continuation of the syphon. They are also used in vacuum buildings in conjunction with screw pumps. Their function in this application is to keep vacuum in the upper vacuum chamber at the same level as in the main volume. In the event of an accident when the pressure rises in the main chamber of the vacuum building, the water from the storage tank will be pushed into the upper chamber and from there by gravity into the spray headers. If the vacuum was not maintained in the upper chamber, pressure there would resist water coming in and the dousing action would not be started. That, of course, is not tolerable.

Vapour Vacuum Pumps

Unlike mechanical vacuum pumps, vapour vacuum pumps operate on an entirely different principle which is not found in other gas pressurizing devices. A jet of vapour issuing from a nozzle is used as a means of pumping. A high velocity vapour jet is directed away from the pump inlet toward the pump discharge. A low pressure area is created, gas is drawn in and imparted directional velocity by the vapour jet and thus removed. There are two main types of vapour pumps - diffusion and ejector pumps.

Diffusion pumps use mercury or oil as a pumping fluid. The fluid is vaporized in the boiler by a heater, issued from the nozzle, recovered and returned to the boiler. These pumps are not suitable for large flows and are not used in our plants.

Ejector pumps use high pressure steam or compressed air as a pumping medium. Due to the availability of steam in our plants, steam ejectors are used at Douglas Point and Bruce NGS to establish and maintain vacuum in the condenser shell. At BHWP steam ejectors are used in the Finishing Unit for the distillation process. They are also used at the Upgrading Units at Pickering NGS. Steam ejectors are high capacity vacuum pumps. They are often designed as two or even more stage units. A typical steam ejector is shown in Figure 7.

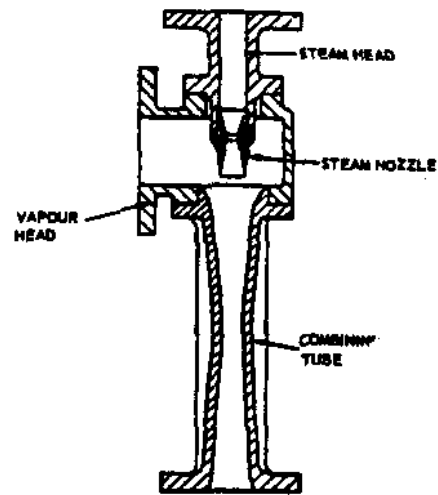

Figure 7

ASSIGNMENT

1. Give the basic classification of vacuum pumps.
2. What type of vacuum pumps are used:
 - (a) in Vacuum Building main chamber?
 - (b) in CCW Systems?
 - (c) Finishing Unit at BHWP?
3. Explain the operation of:
 - (a) liquid-piston vacuum pump.
 - (b) steam ejector.
4. Which vacuum pumps are suitable for large capacities?

K. Mika